

Detail 1-1

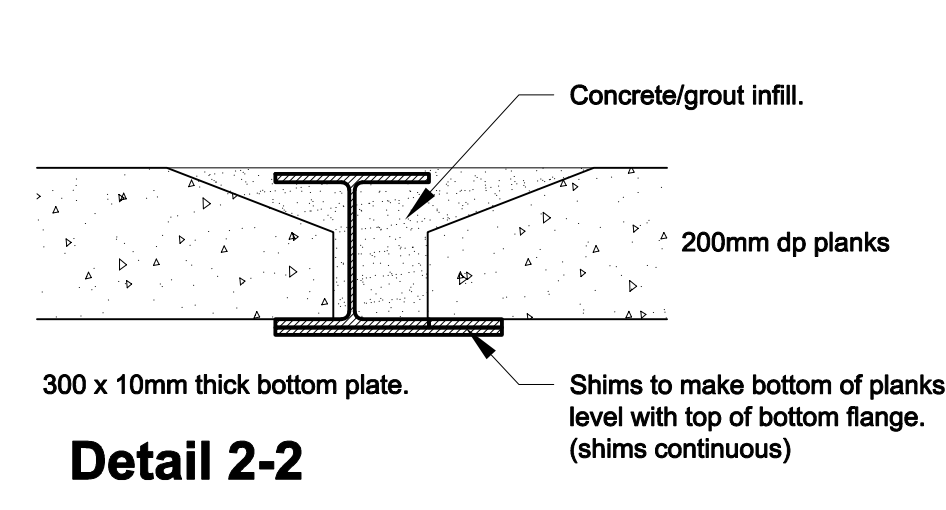

Detail 2-2

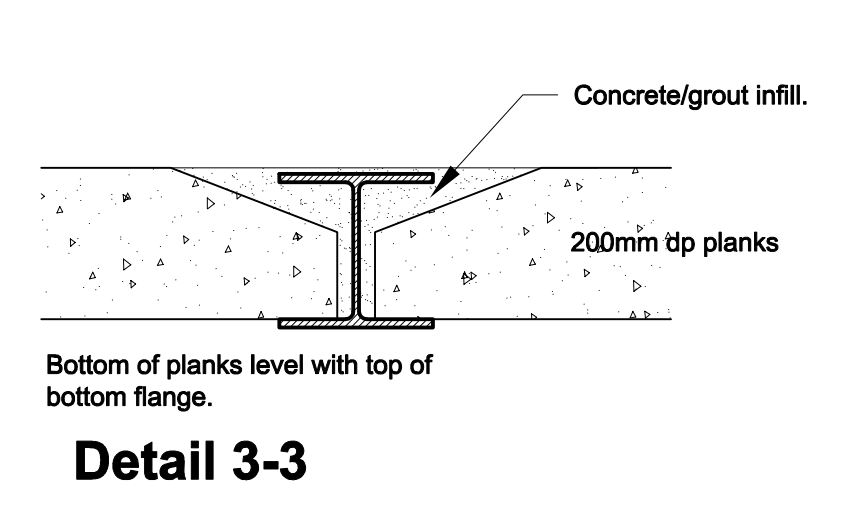

Detail 3-3

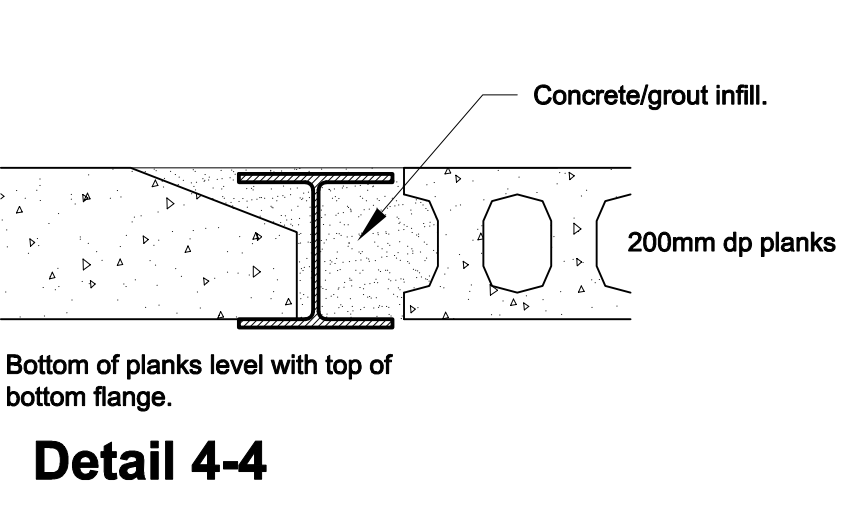

Detail 4-4

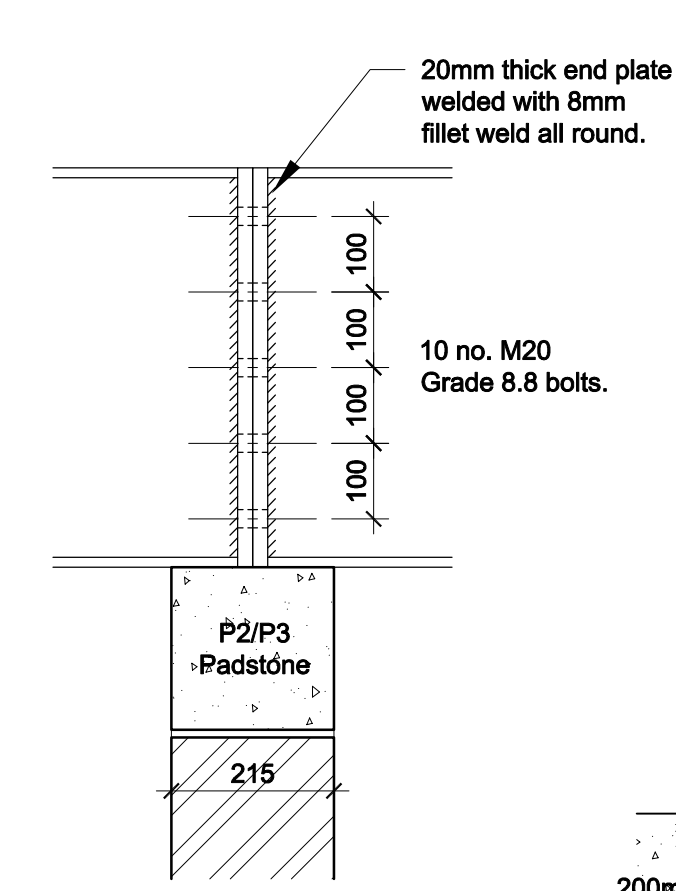

Detail 5-5

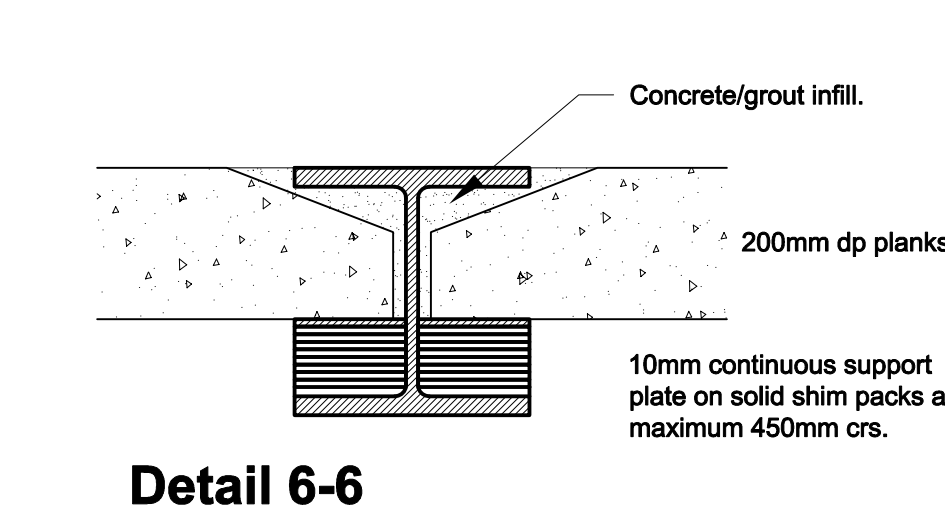

Detail 6-6

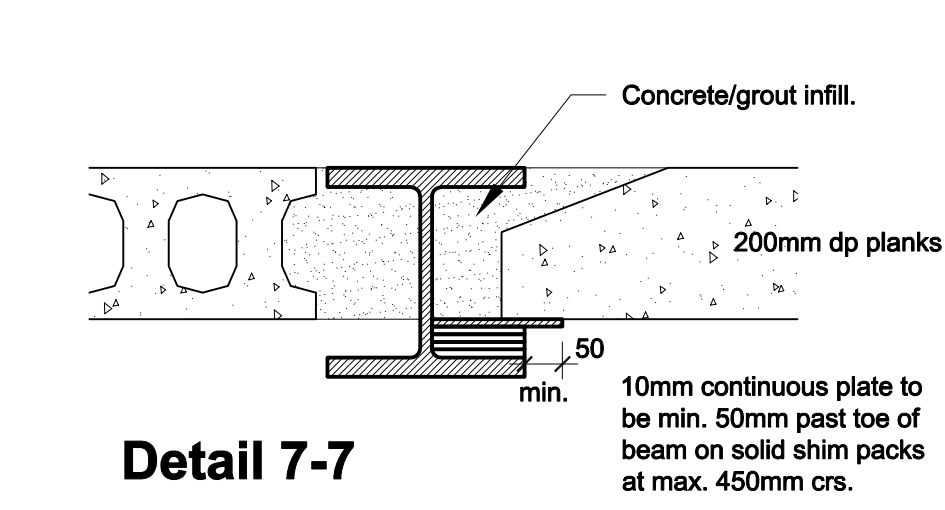

Detail 7-7

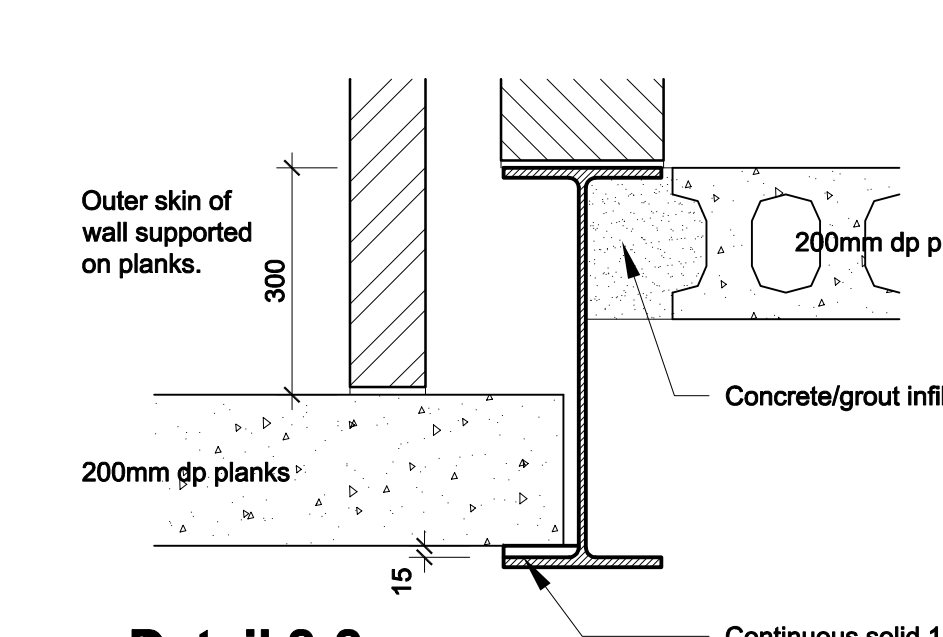

Detail 8-8

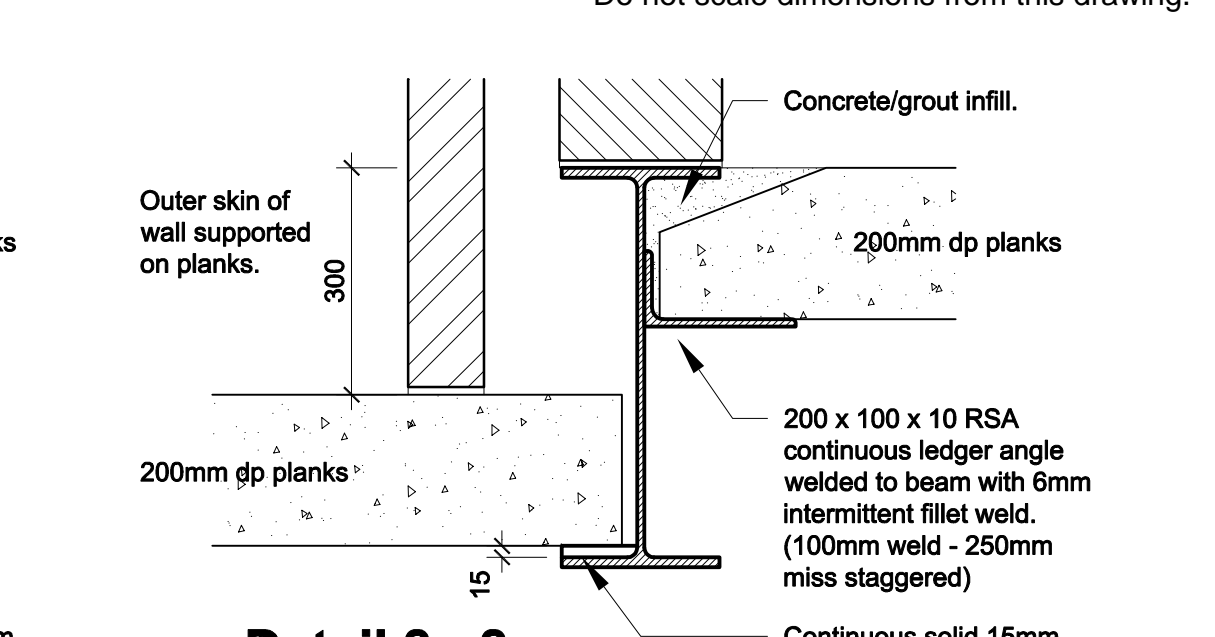

Detail 8a-8a

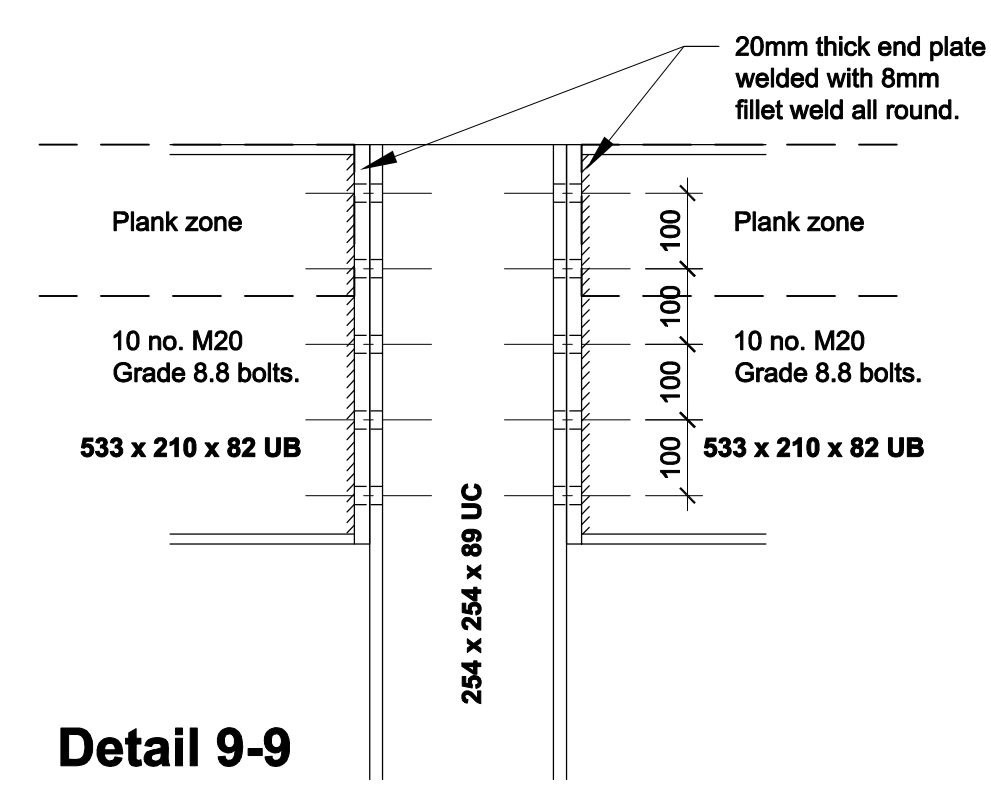

Detail 9-9

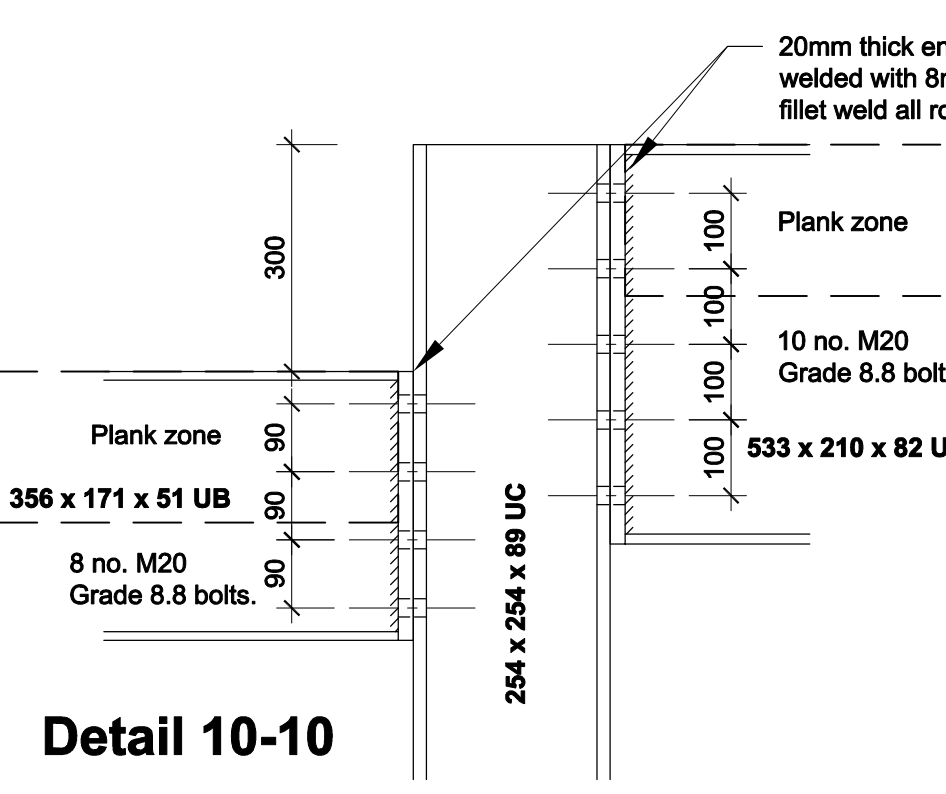

Detail 10-10

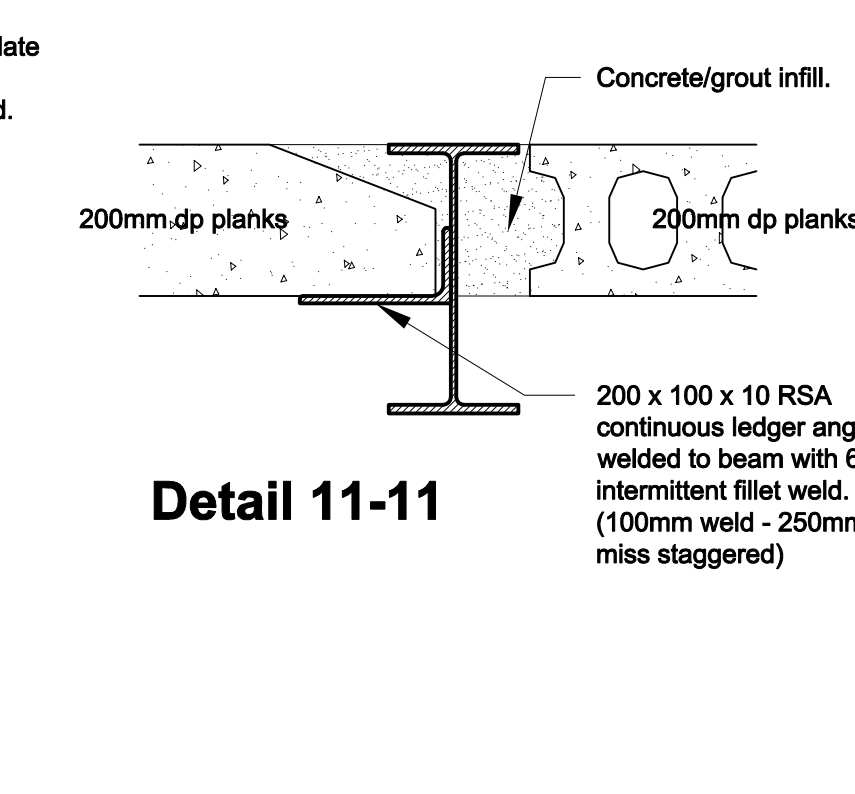

Detail 11-11

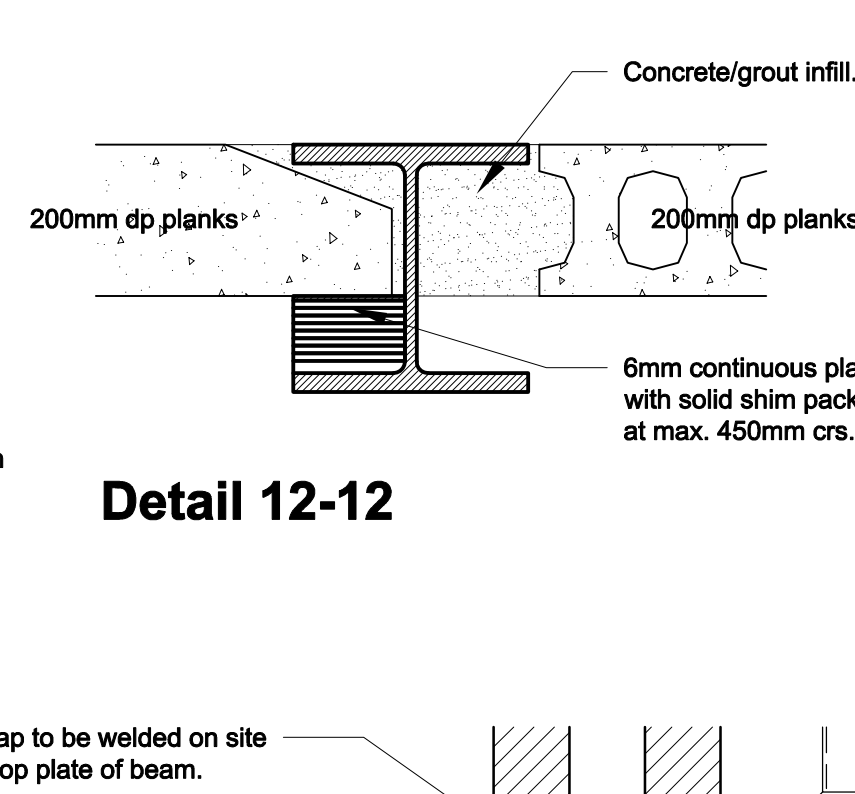

Detail 12-12

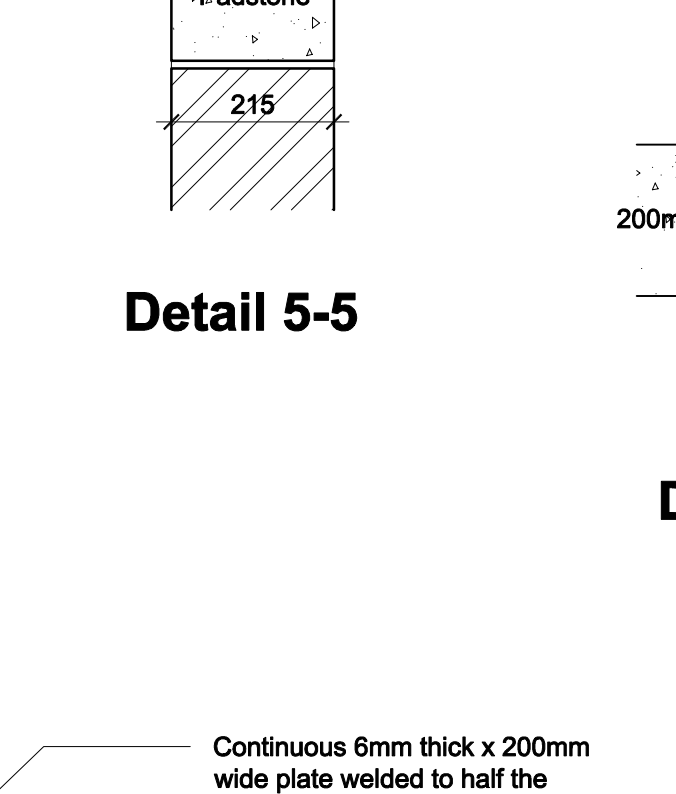

Detail 13-13

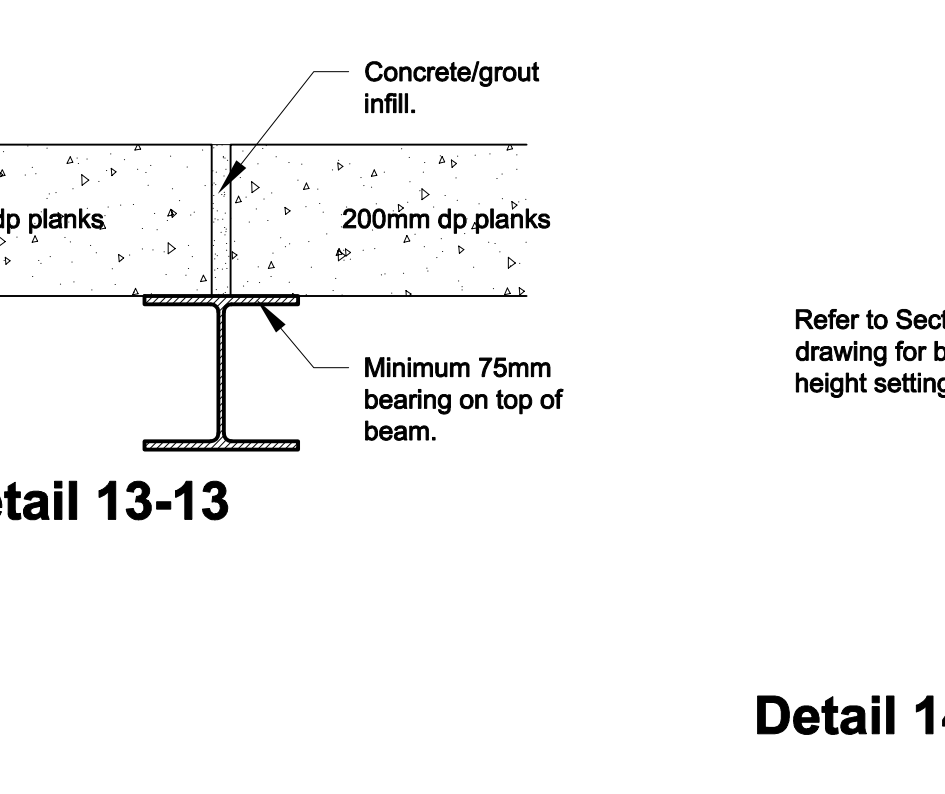

Detail 14-14

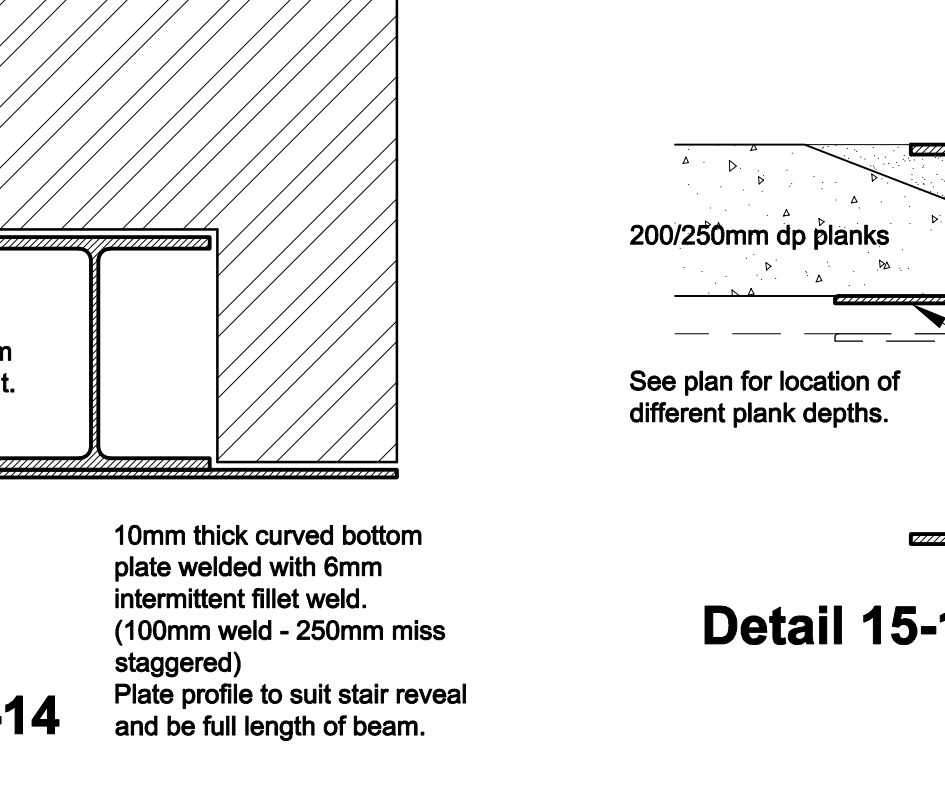

Detail 15-15

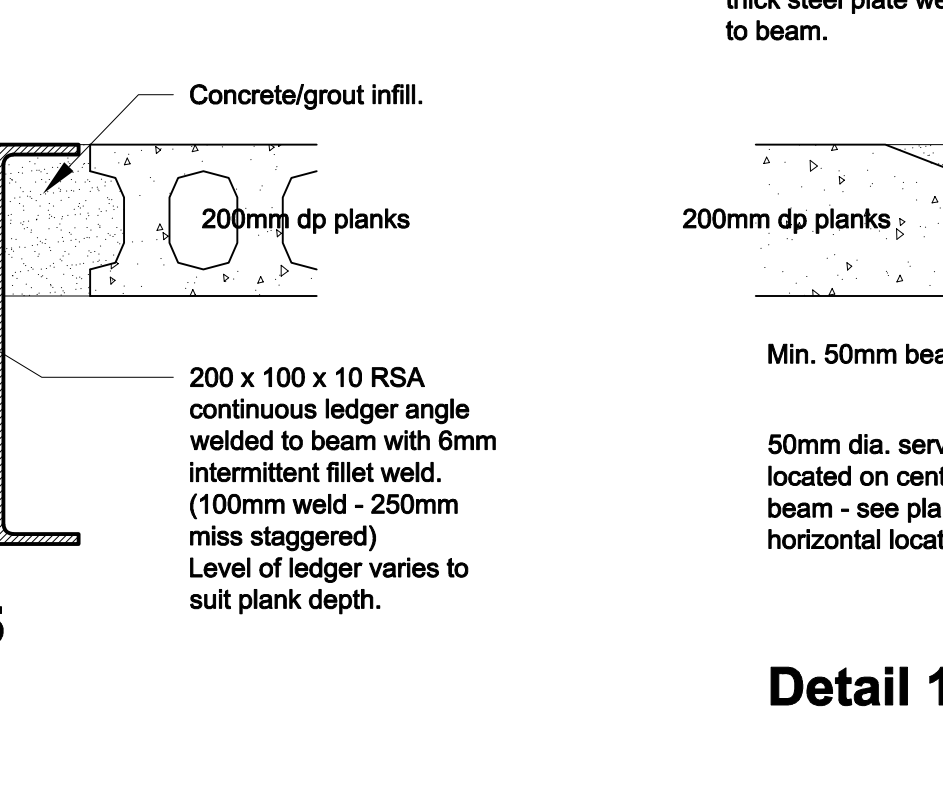

Detail 16-16

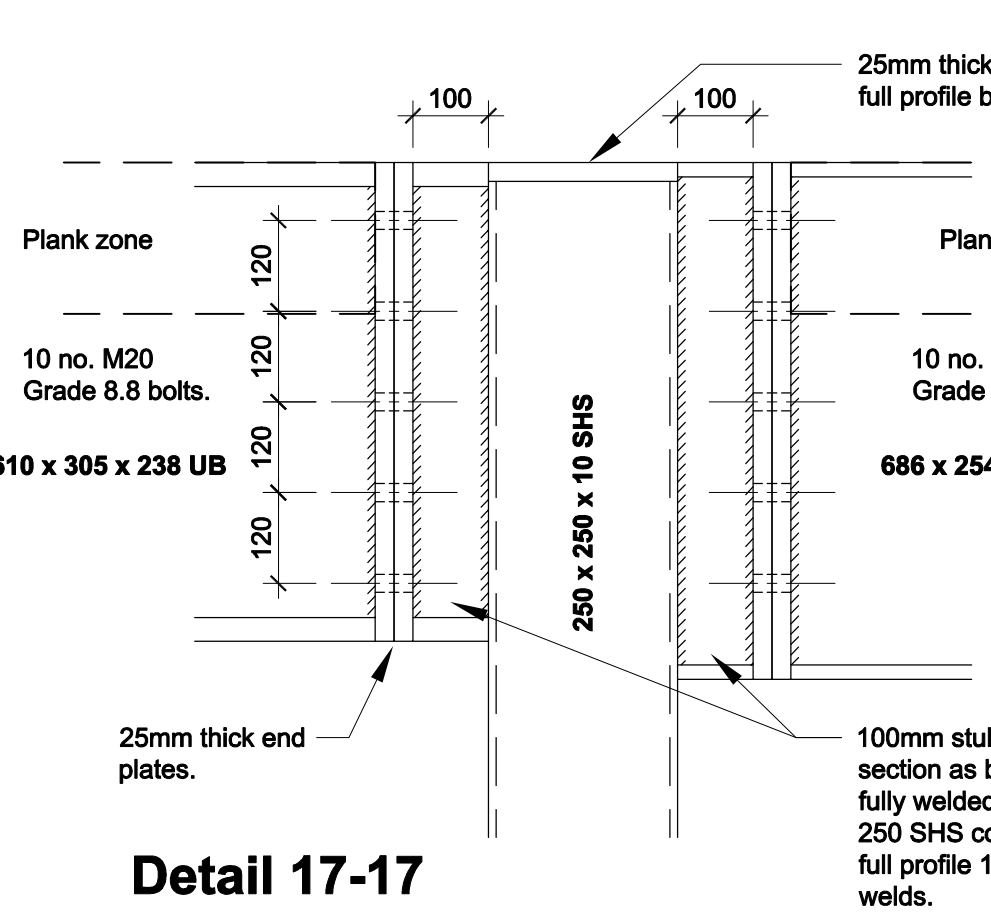

Detail 17-17

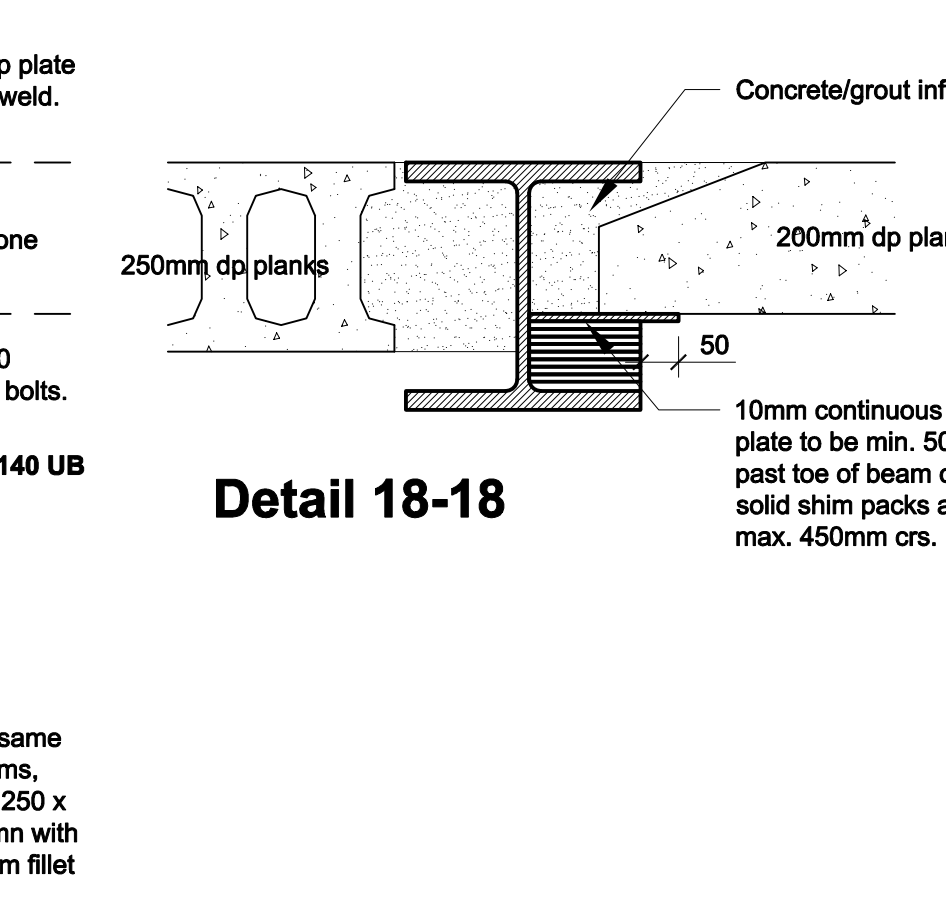

Detail 18-18

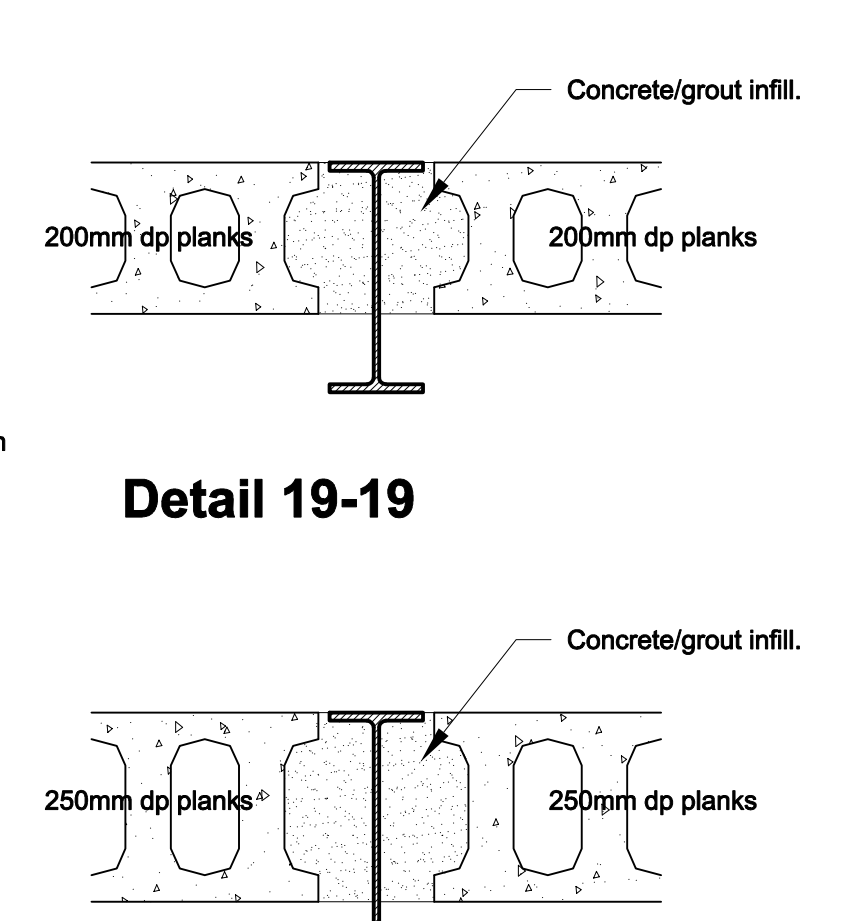

Detail 19-19

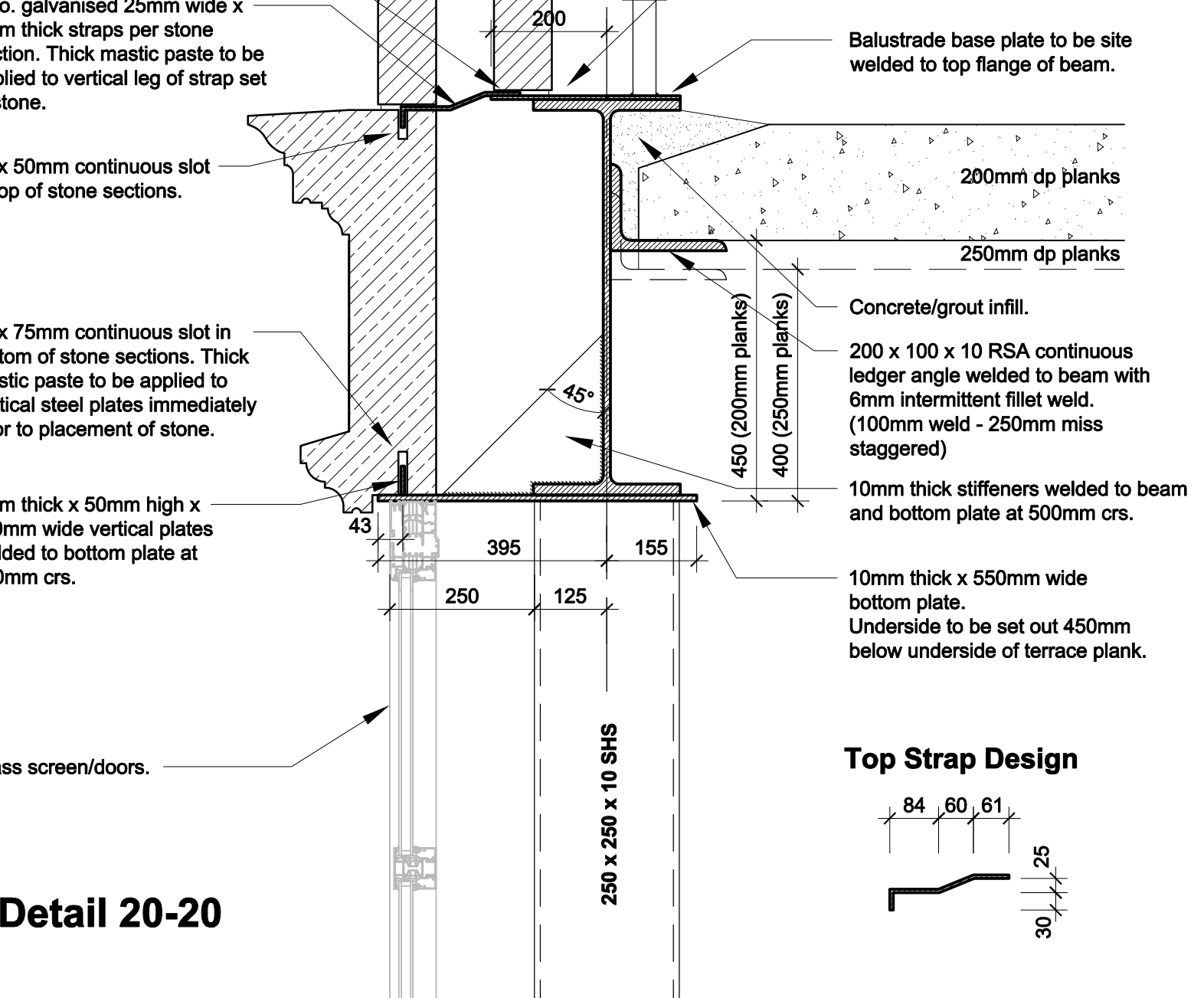

Detail 20-20

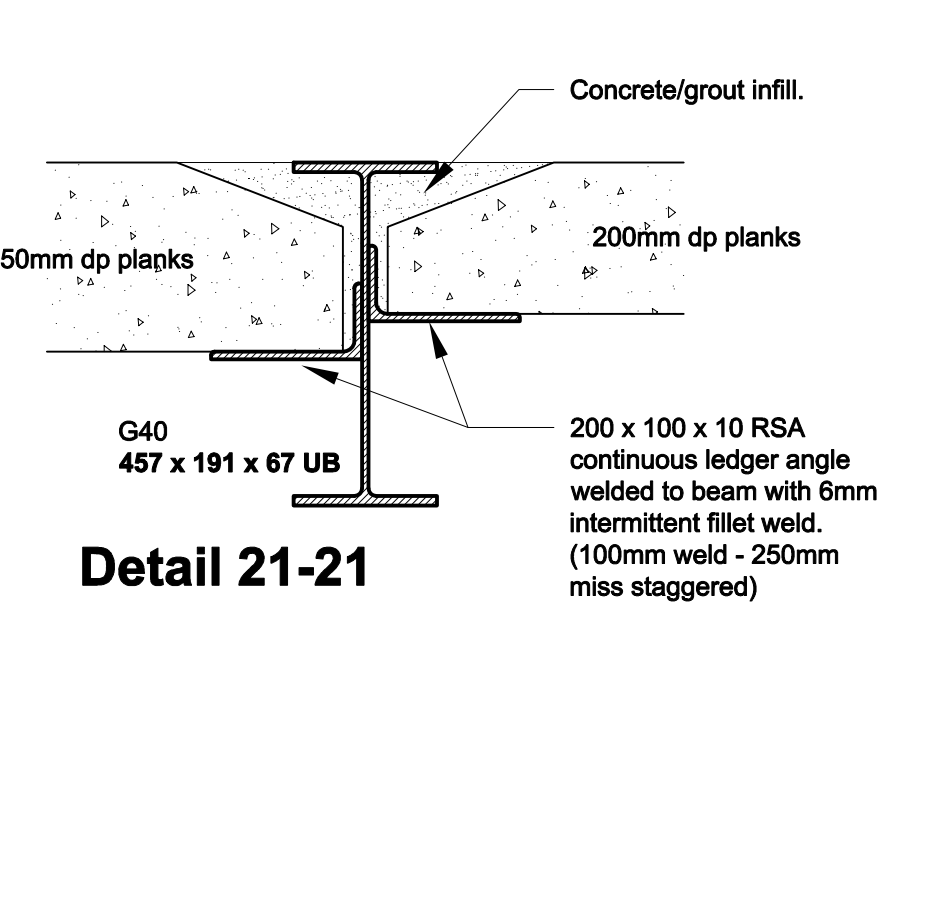

Detail 21-21

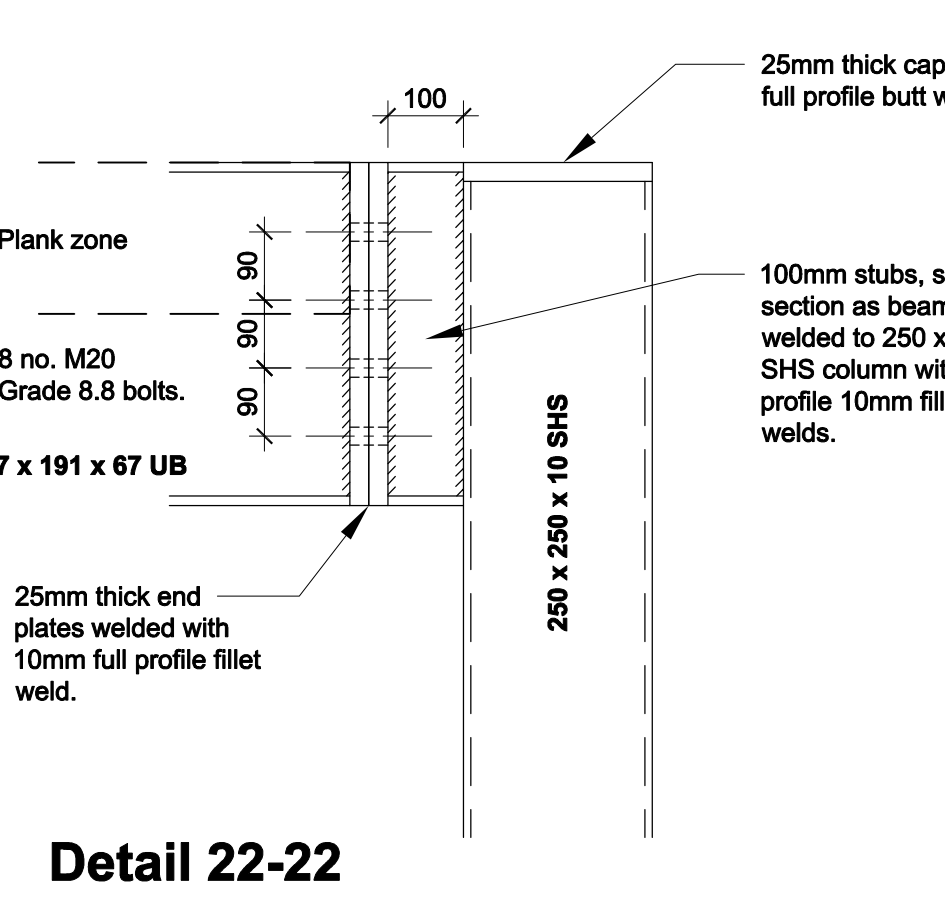

Detail 22-22

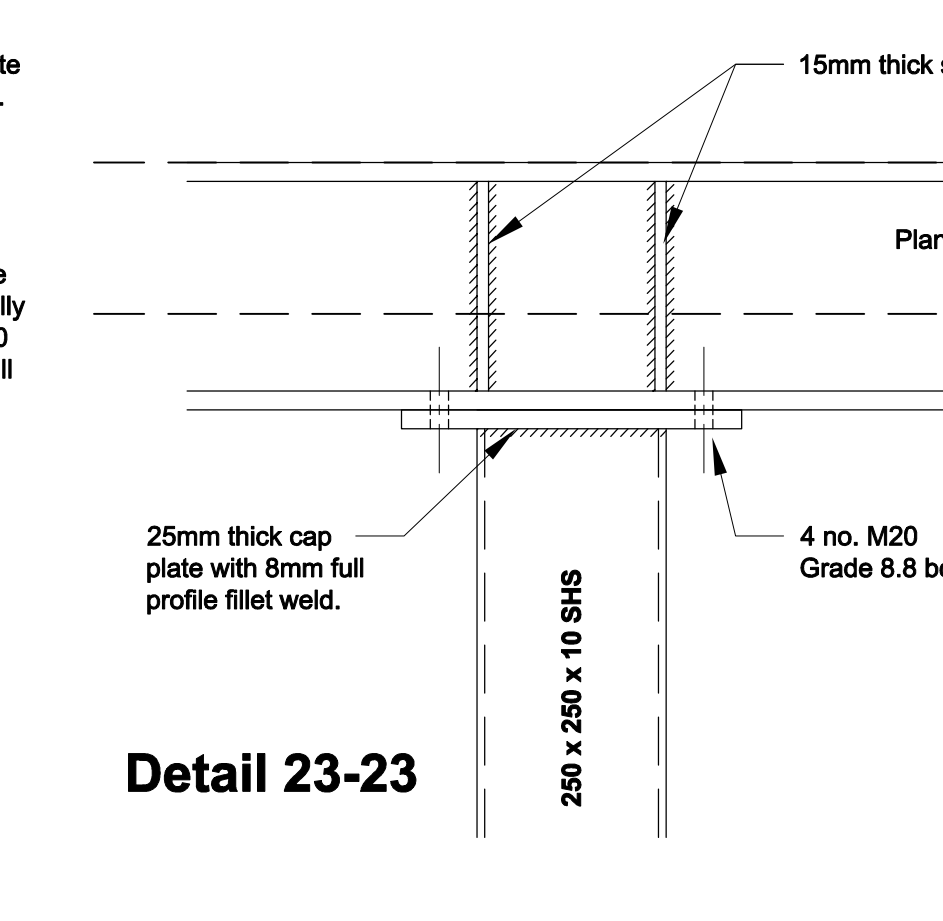

Detail 23-23

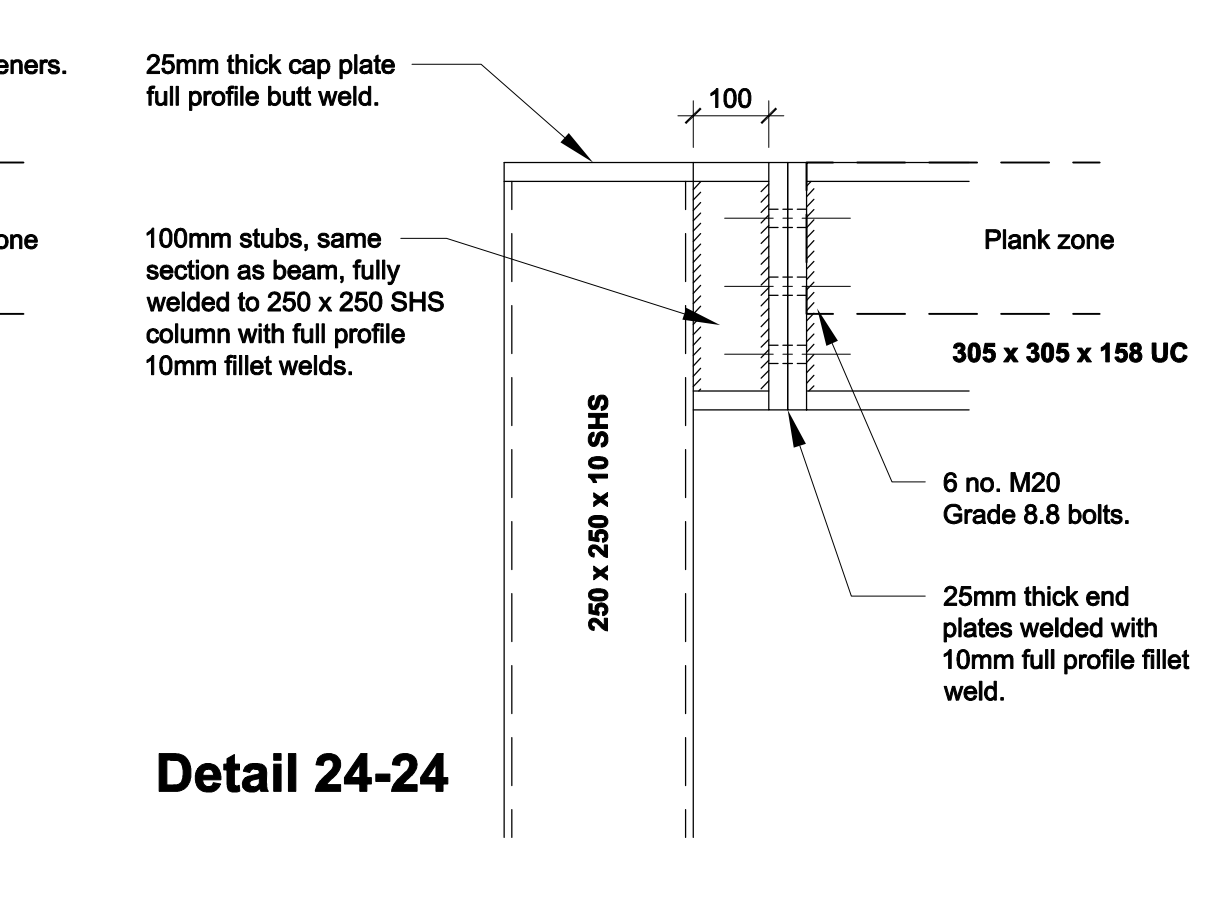

Detail 24-24

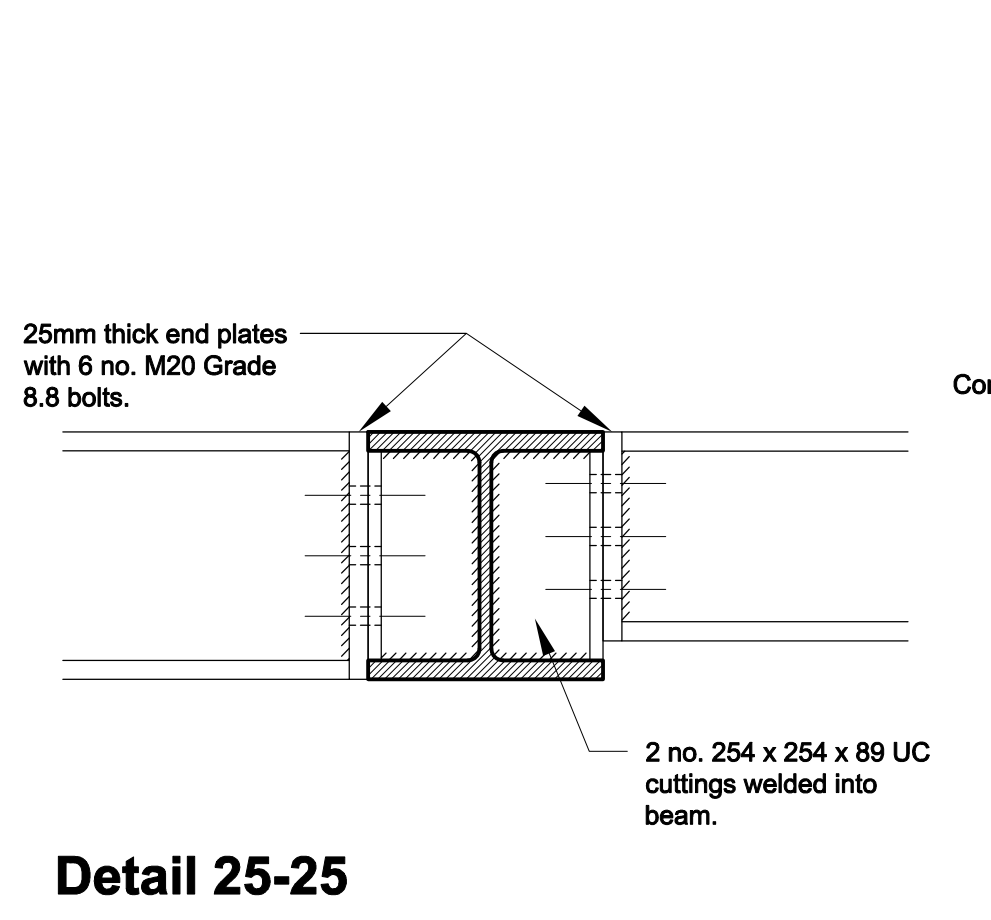

Detail 25-25

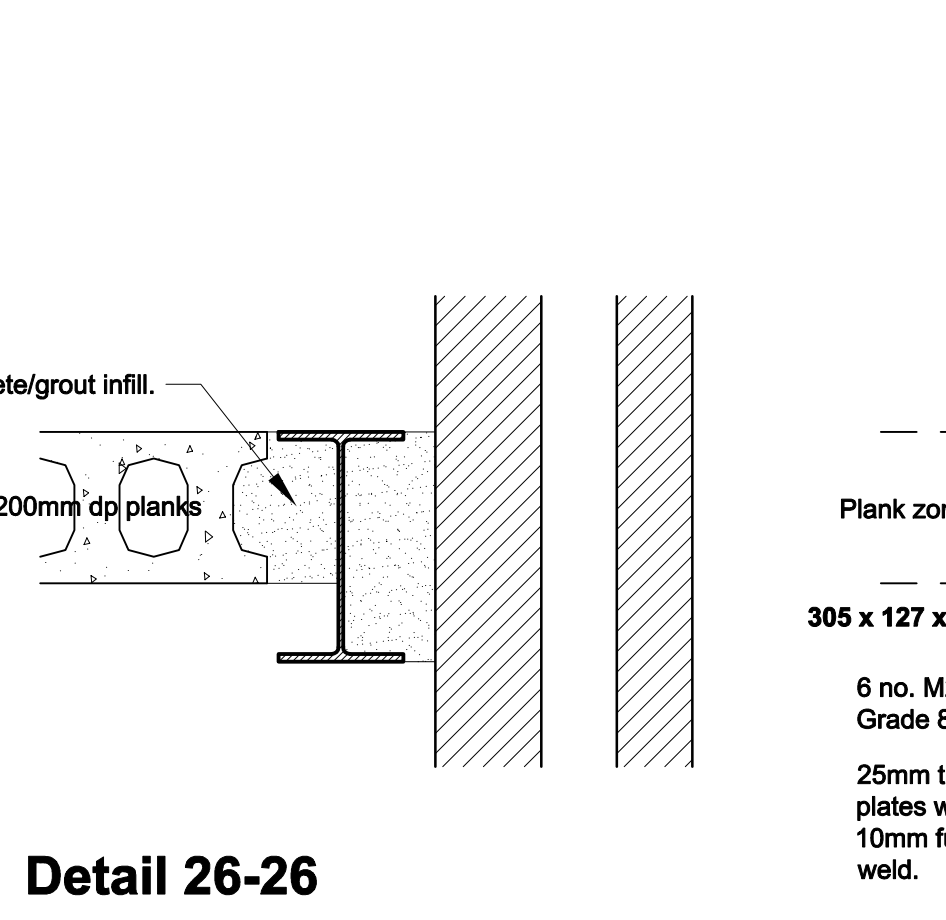

Detail 26-26

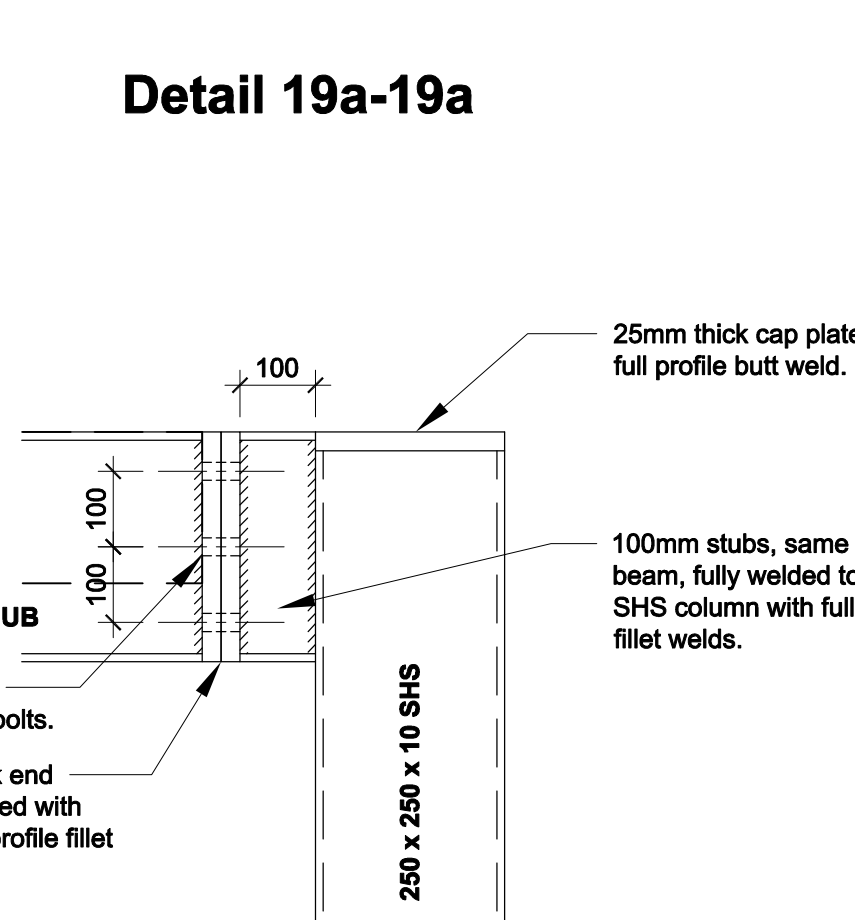

Detail 27-27

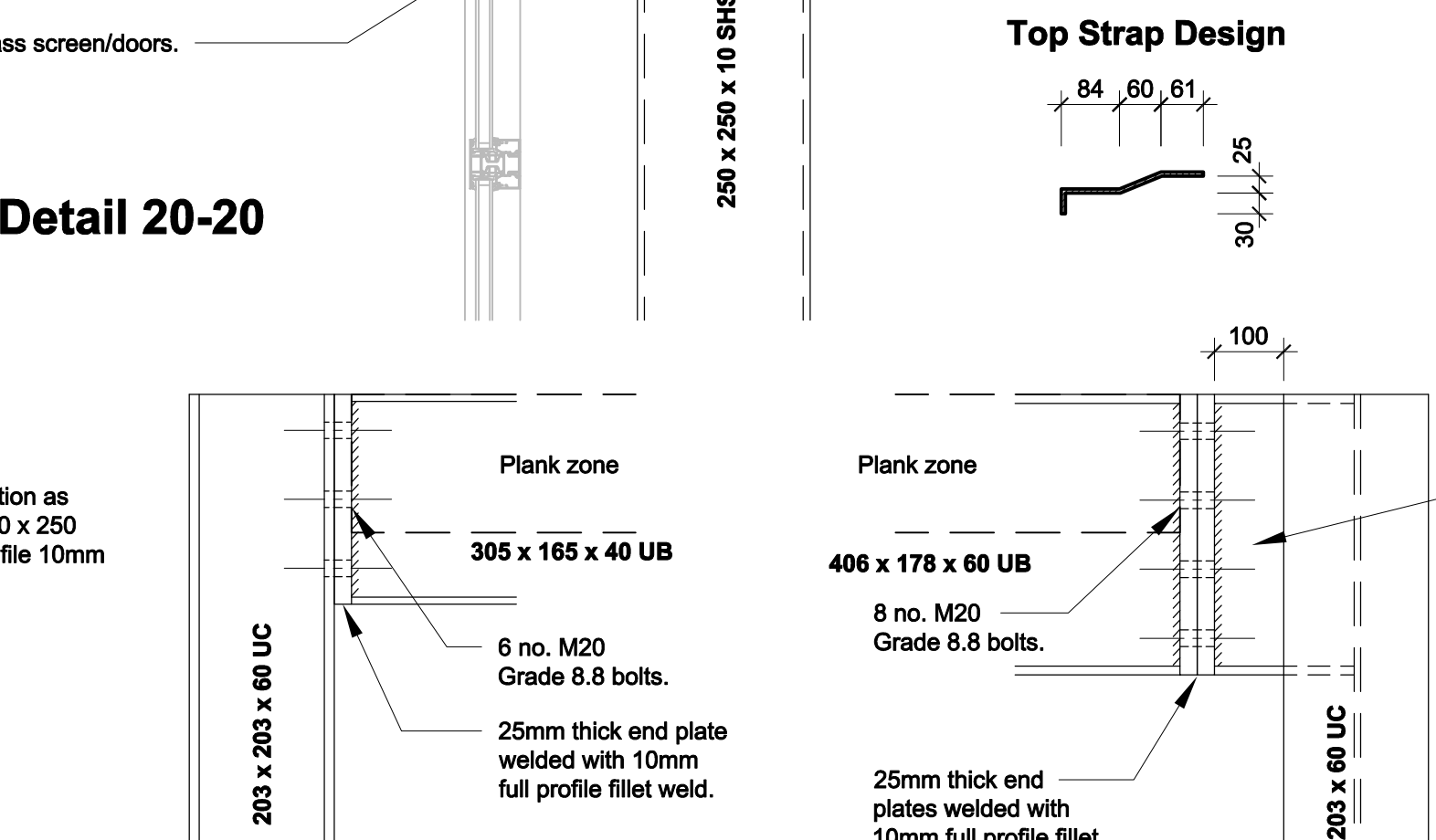

Detail 28-28

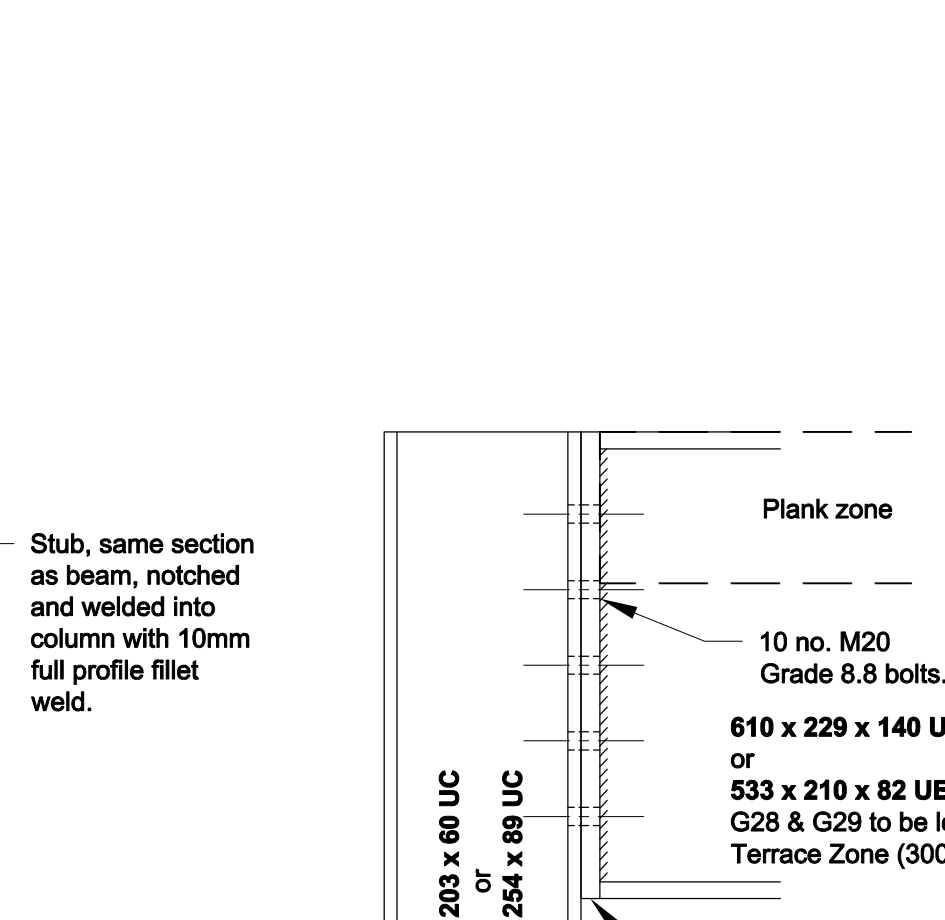

Detail 29-29

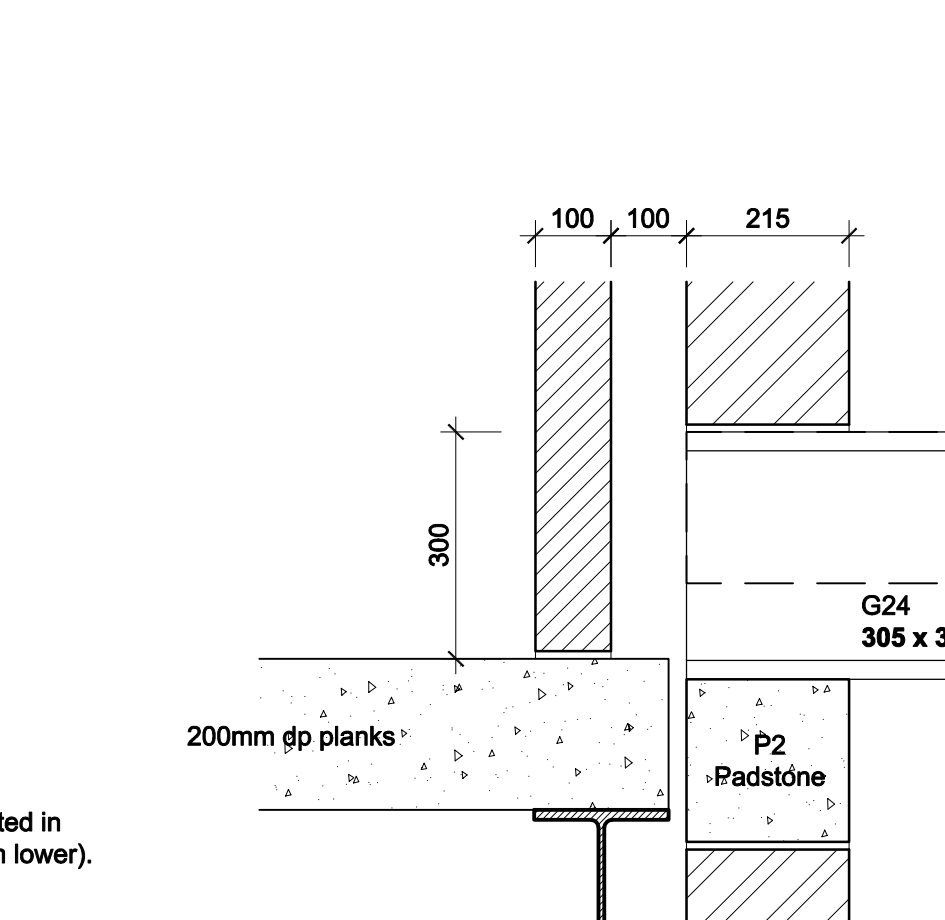

Detail 30-30

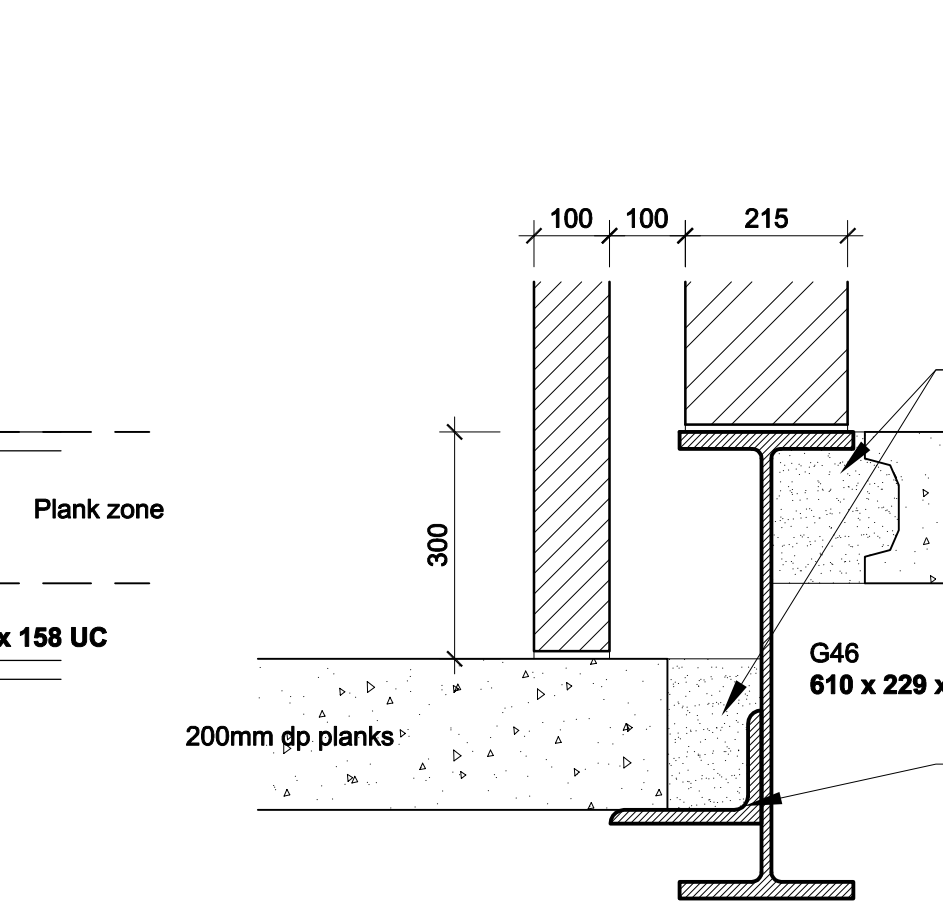

Detail 31-31

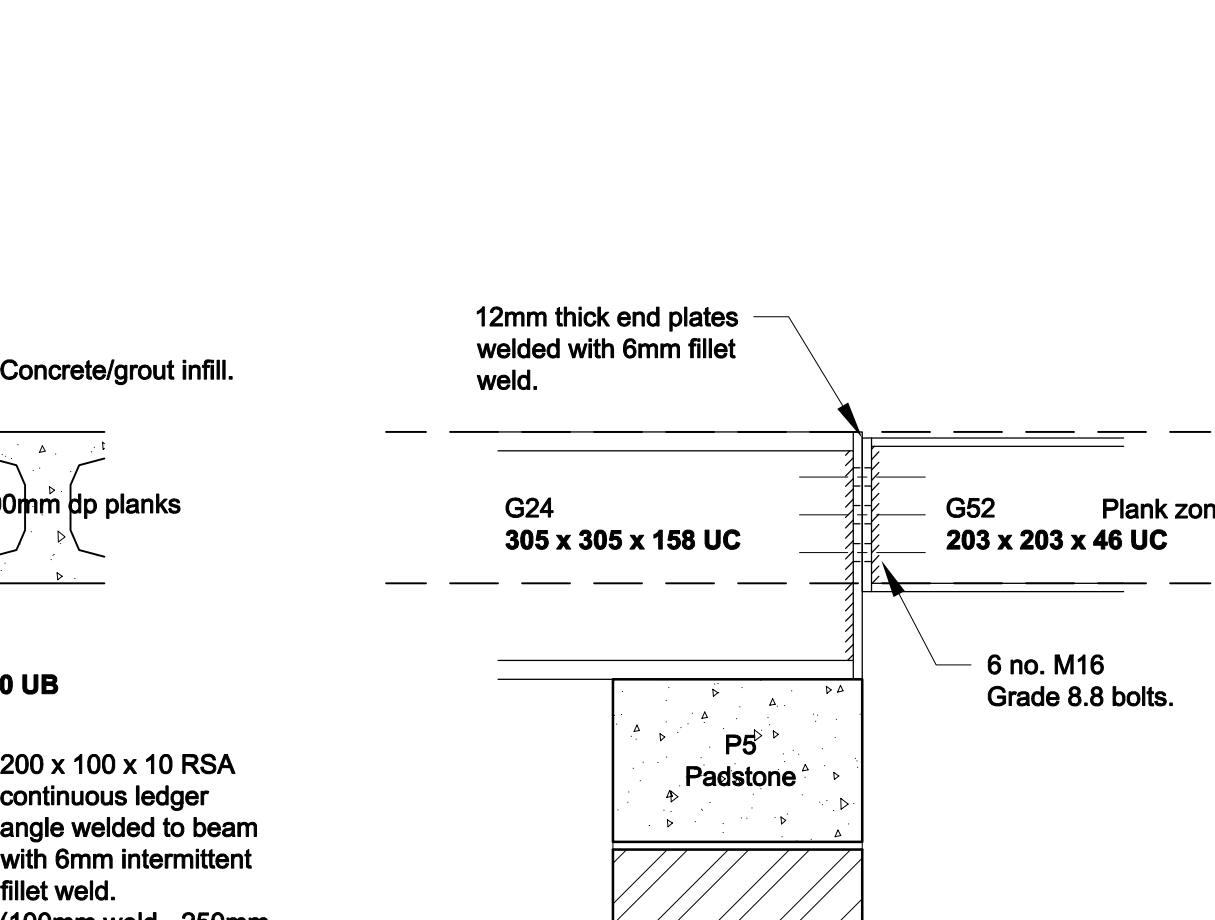

Detail 32-32

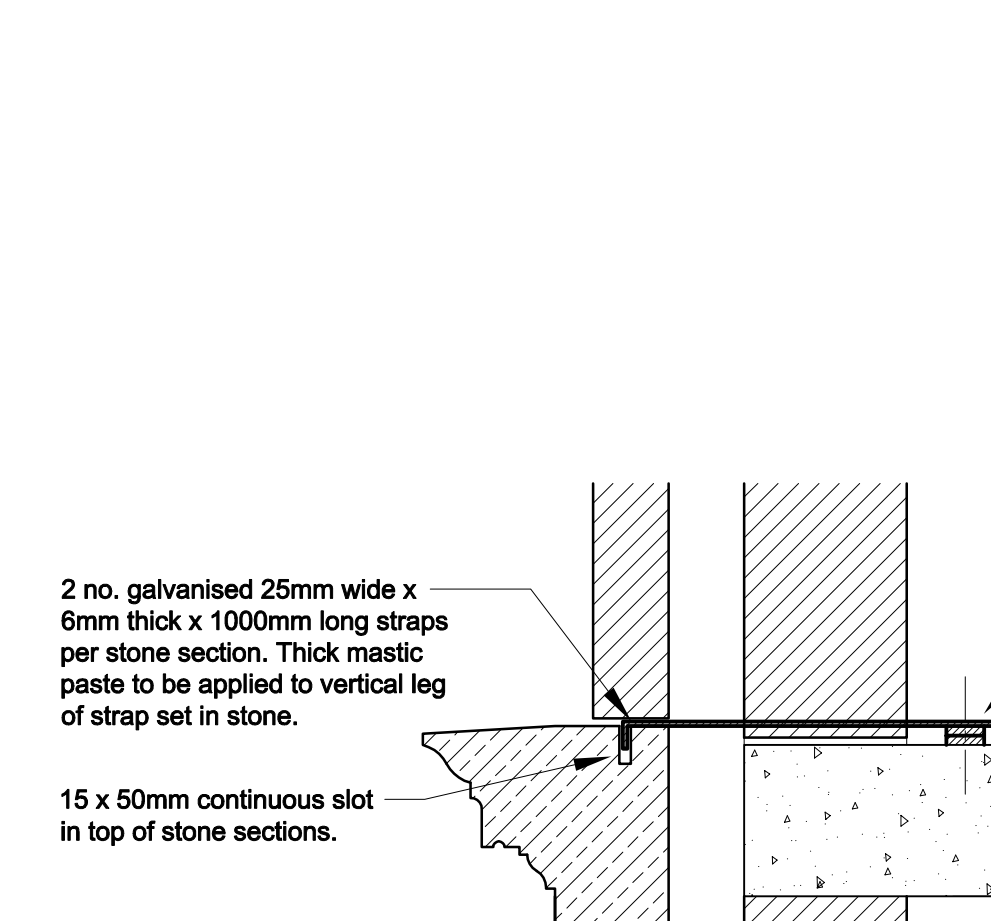

Detail 33-33

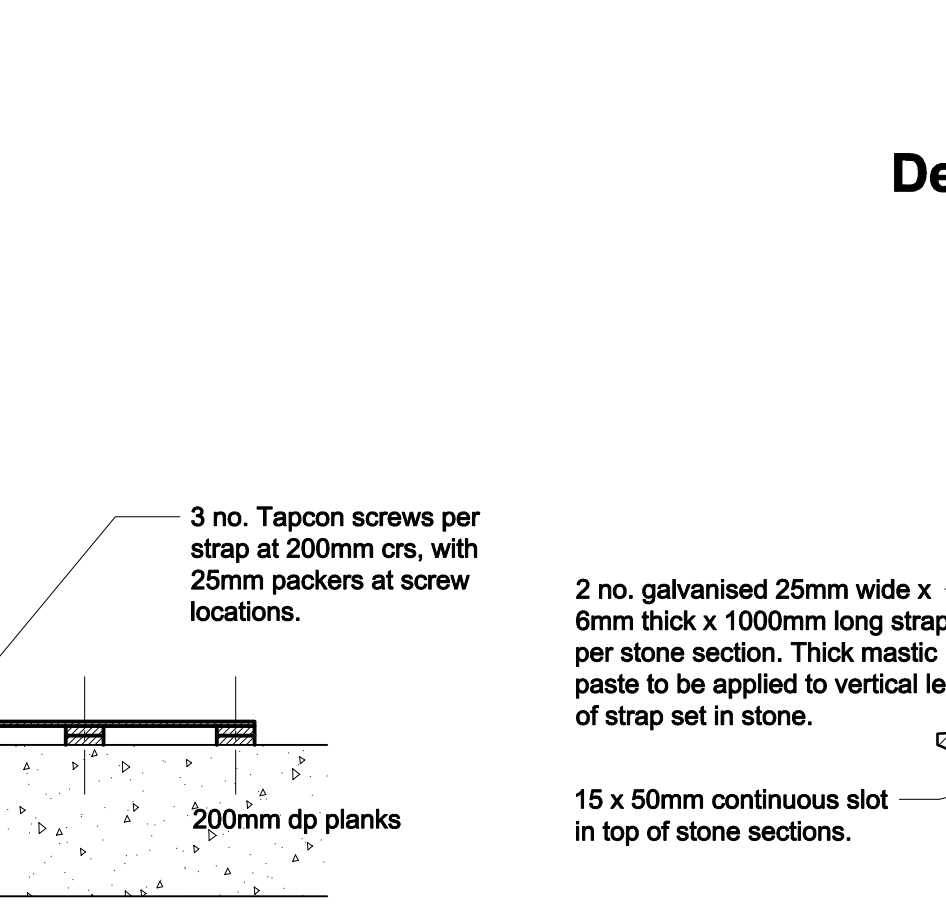

Detail 34-34

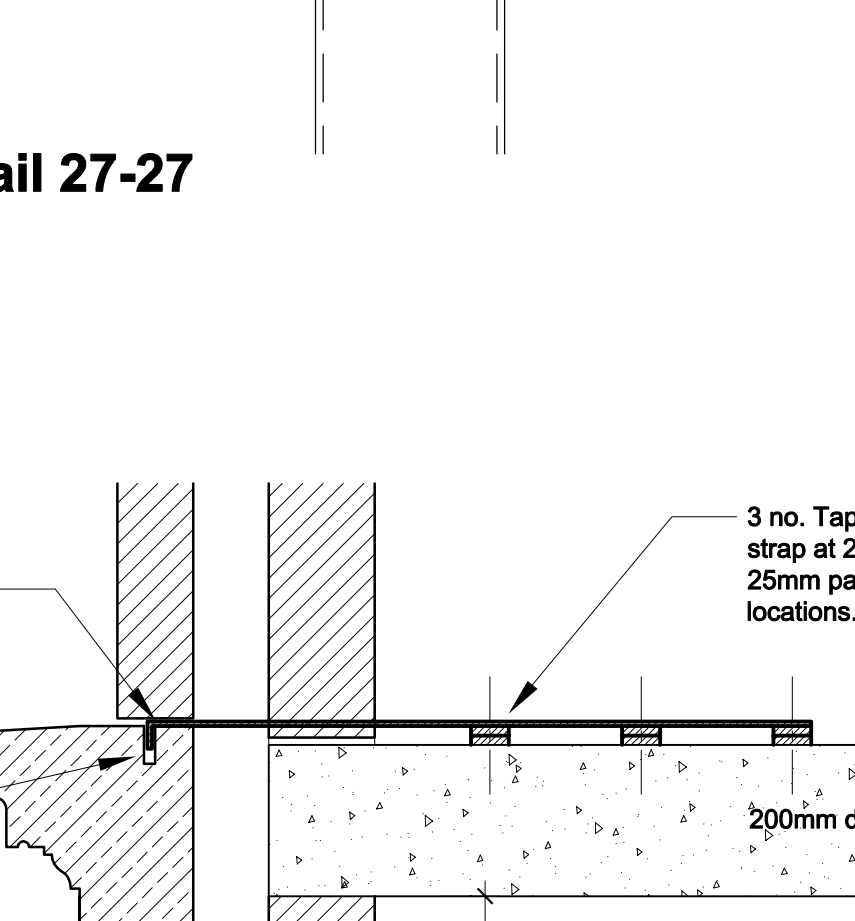

Detail 35-35

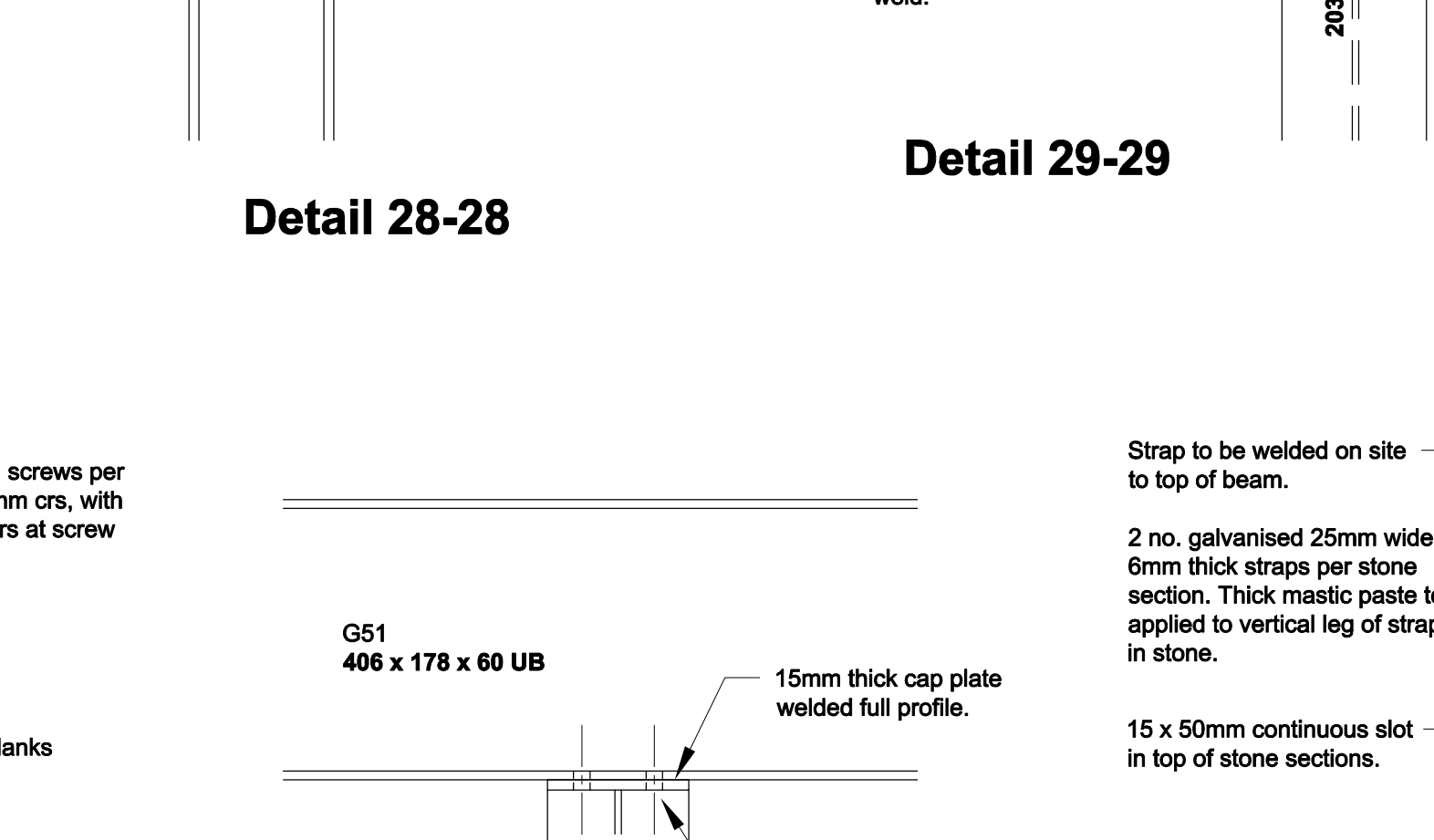

Detail 36-36

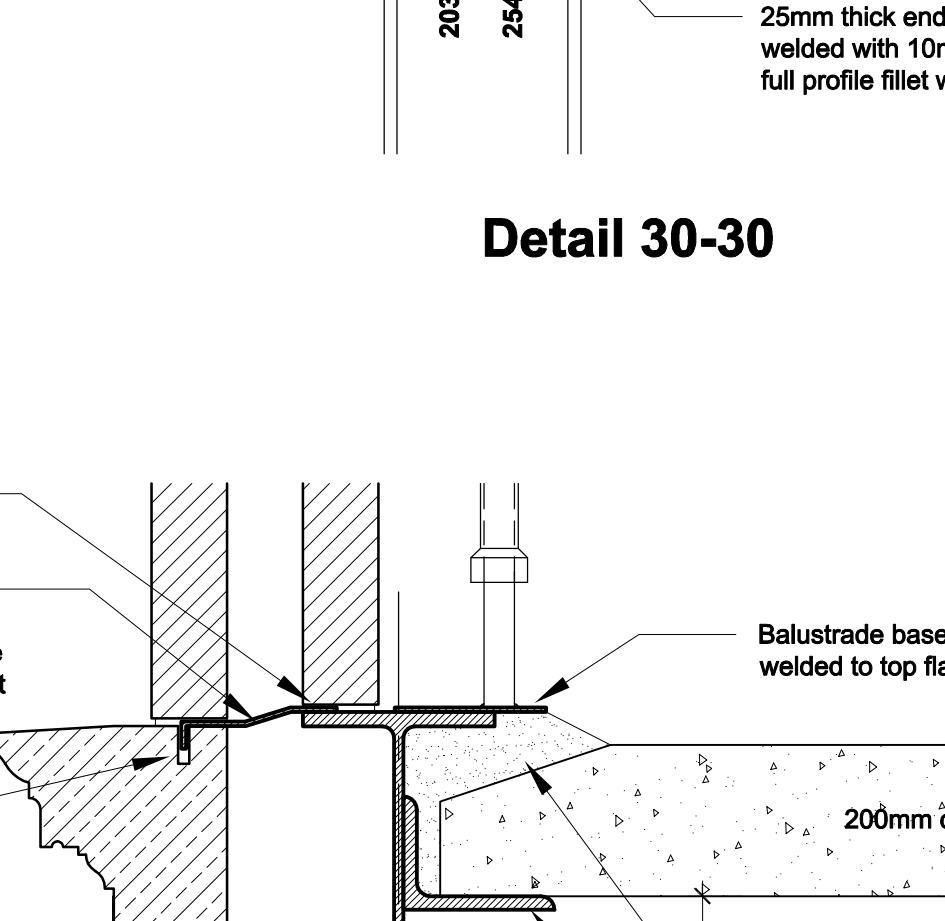

Detail 37-37

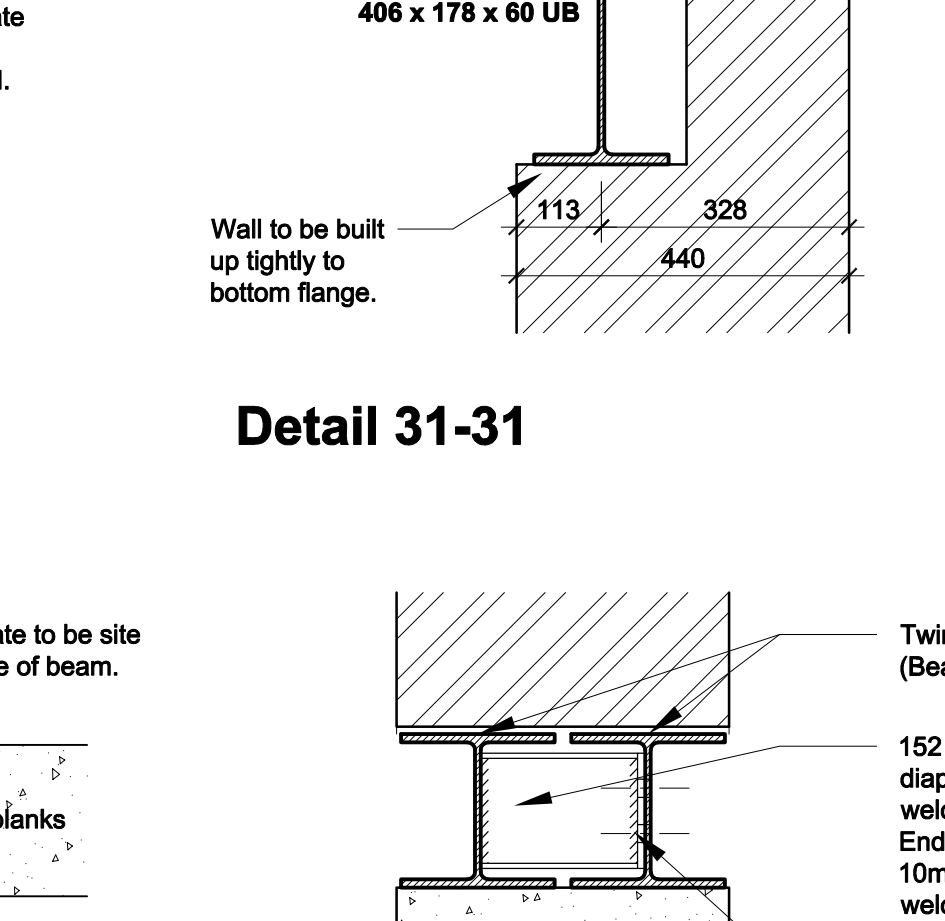

Detail 38-38

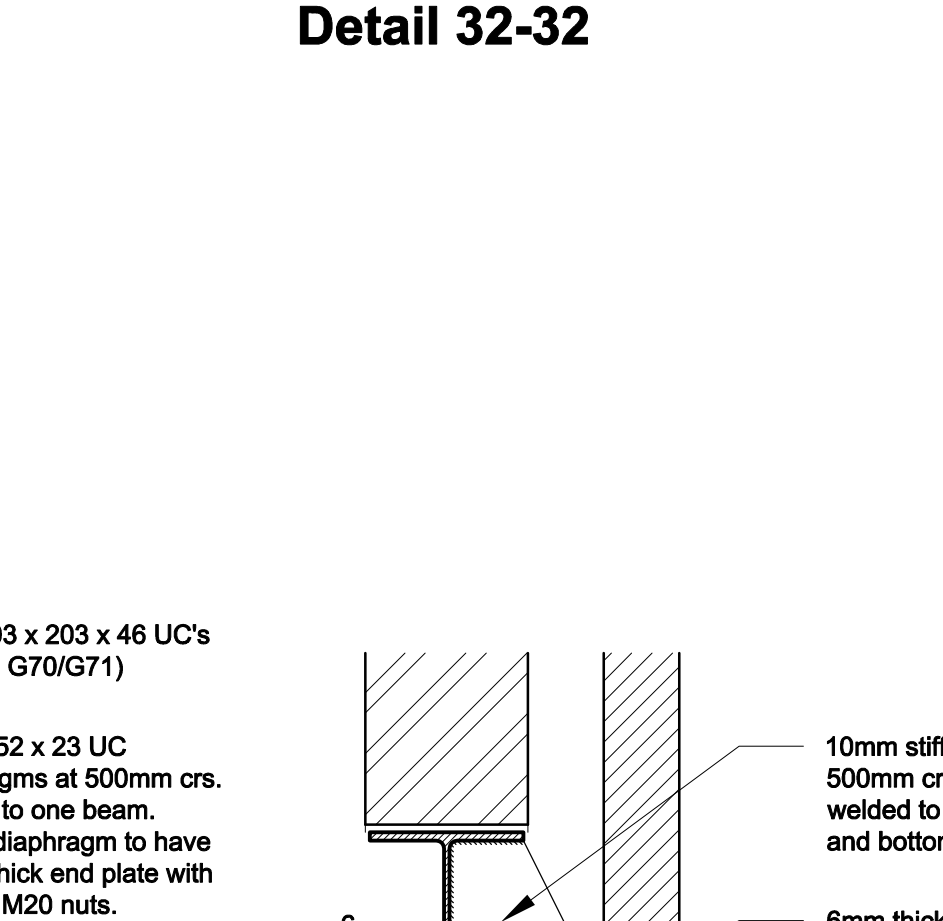

Detail 39-39

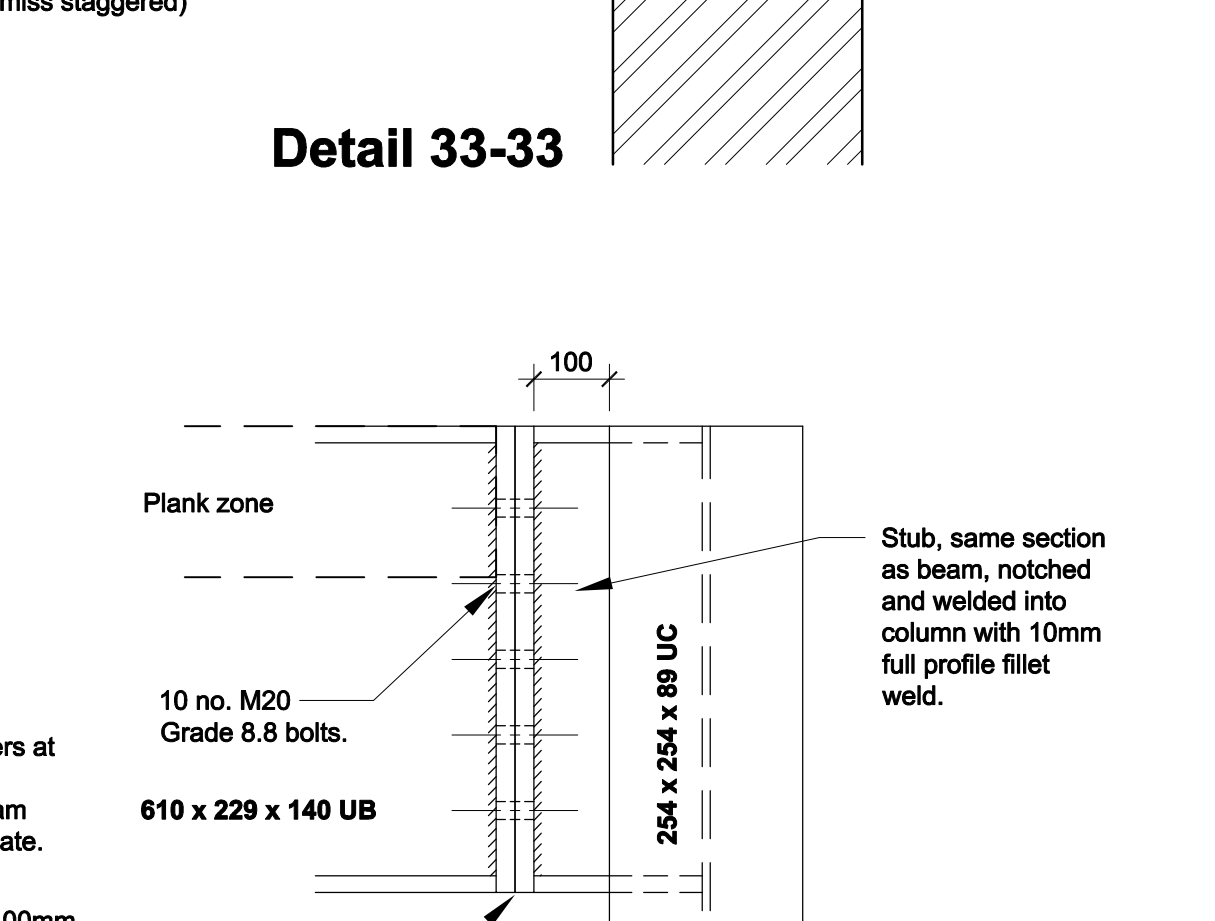

Detail 40-40

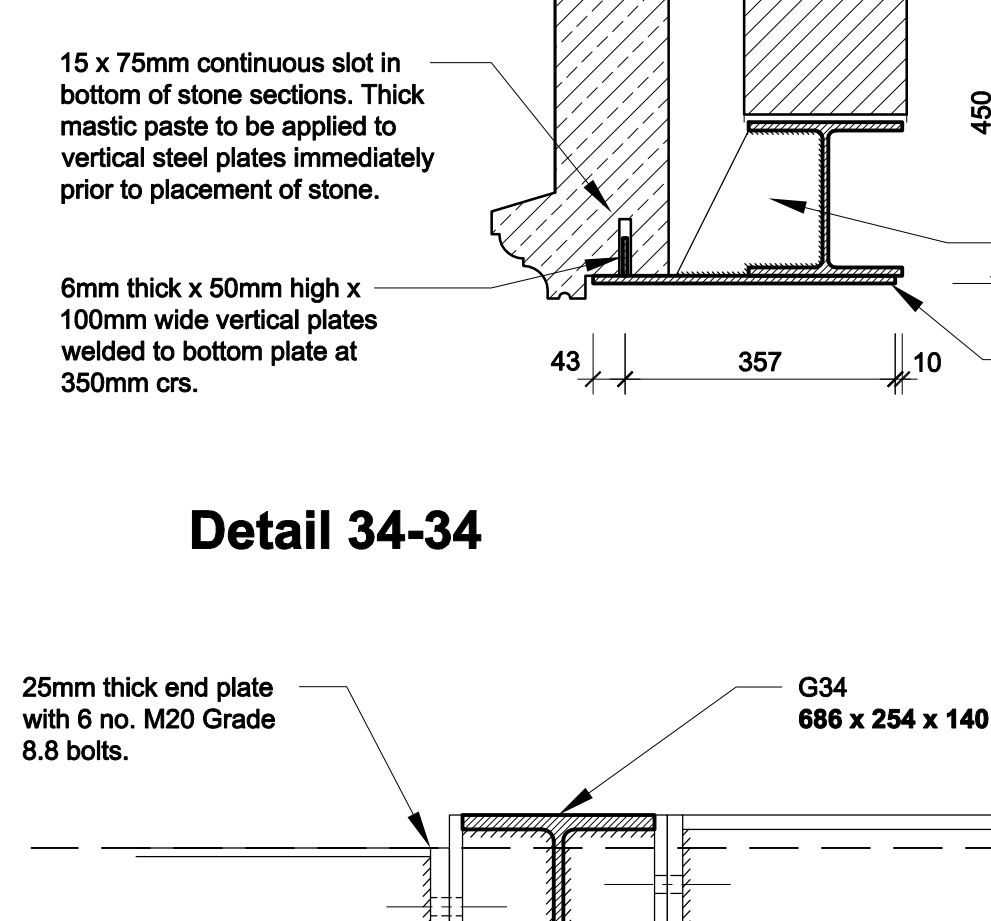

Detail 41-41

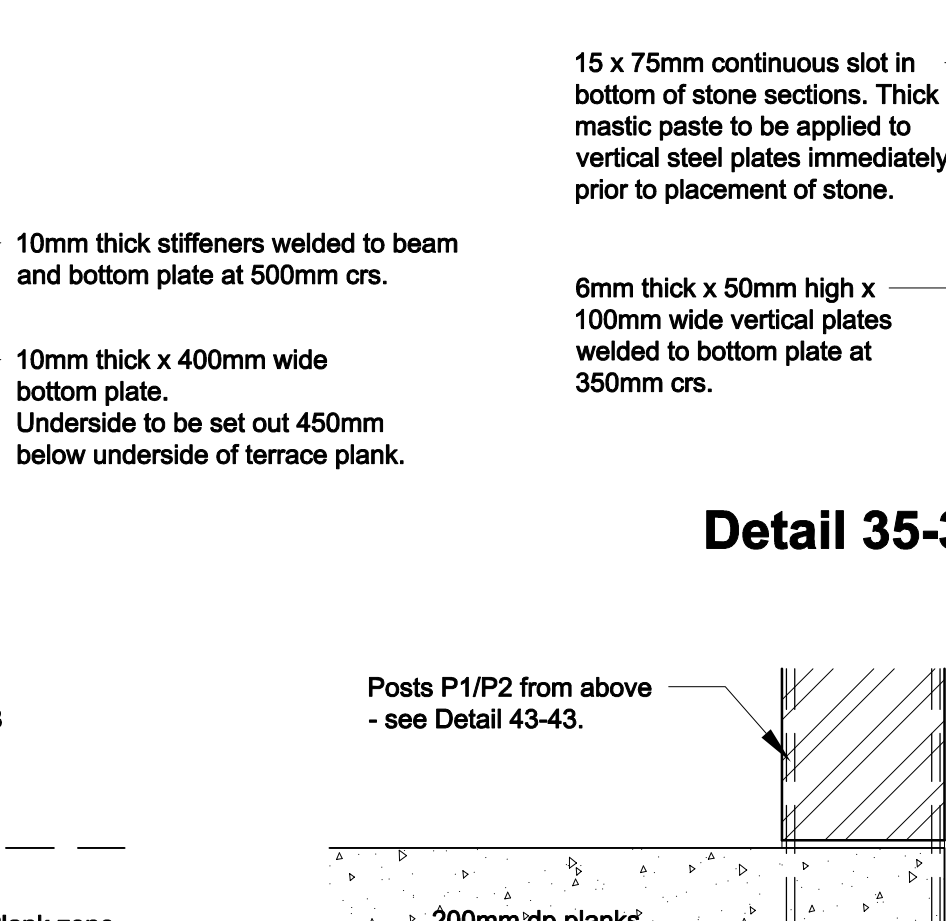

Detail 42-42

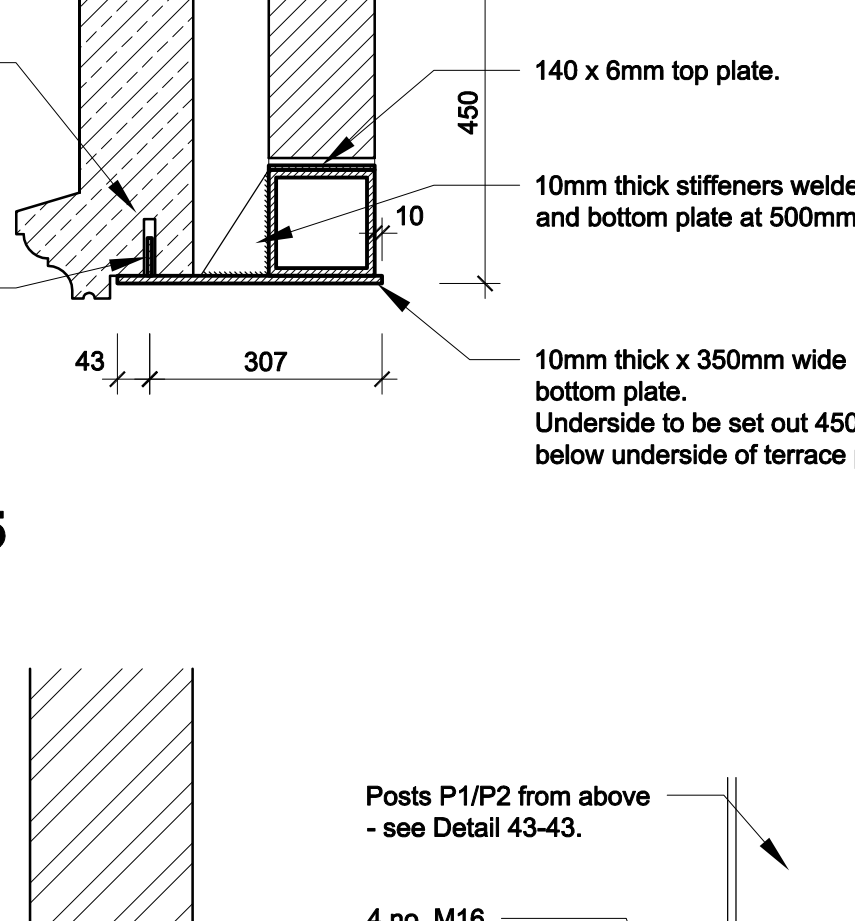

Detail 43-43

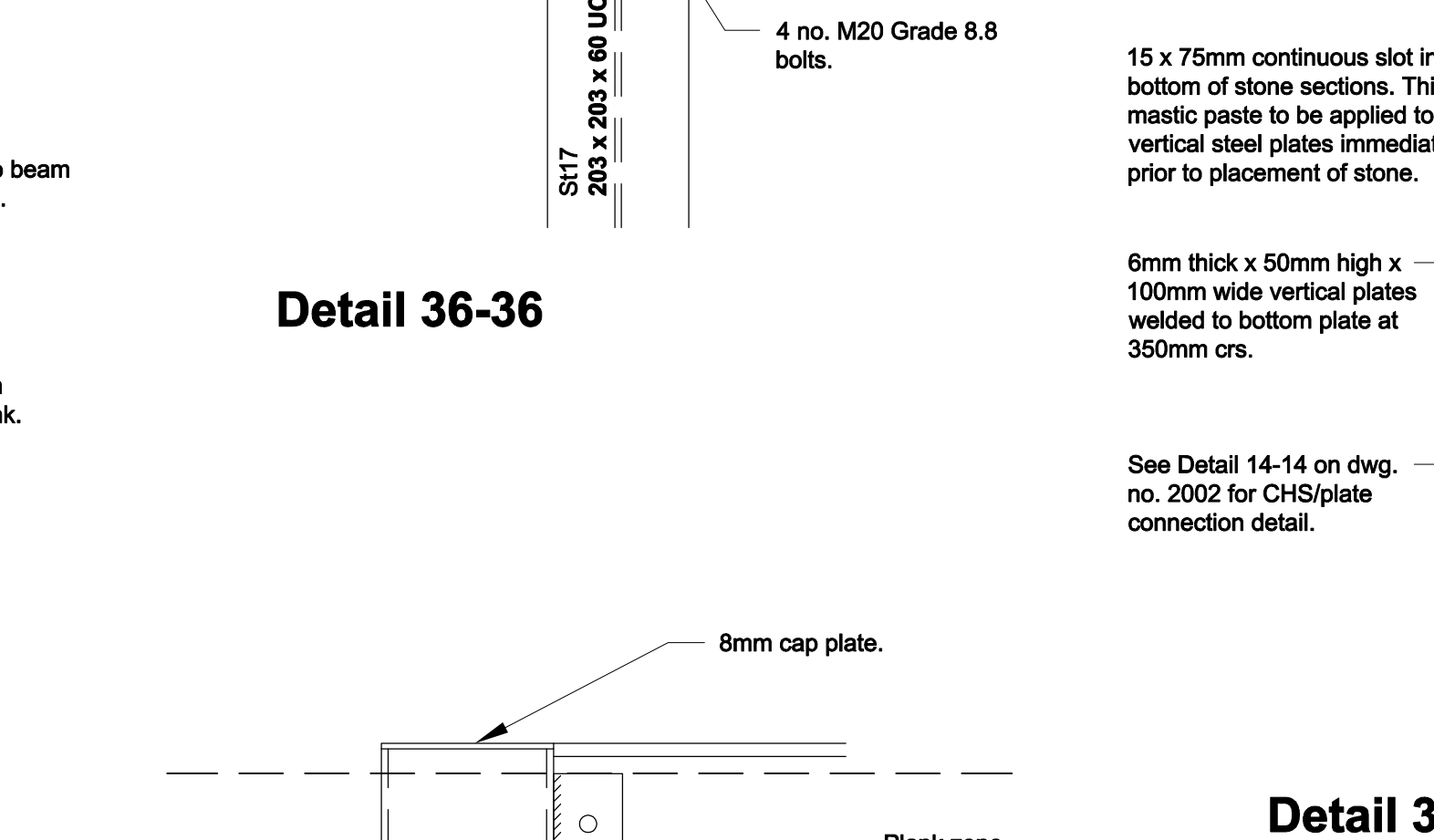

Detail 44-44

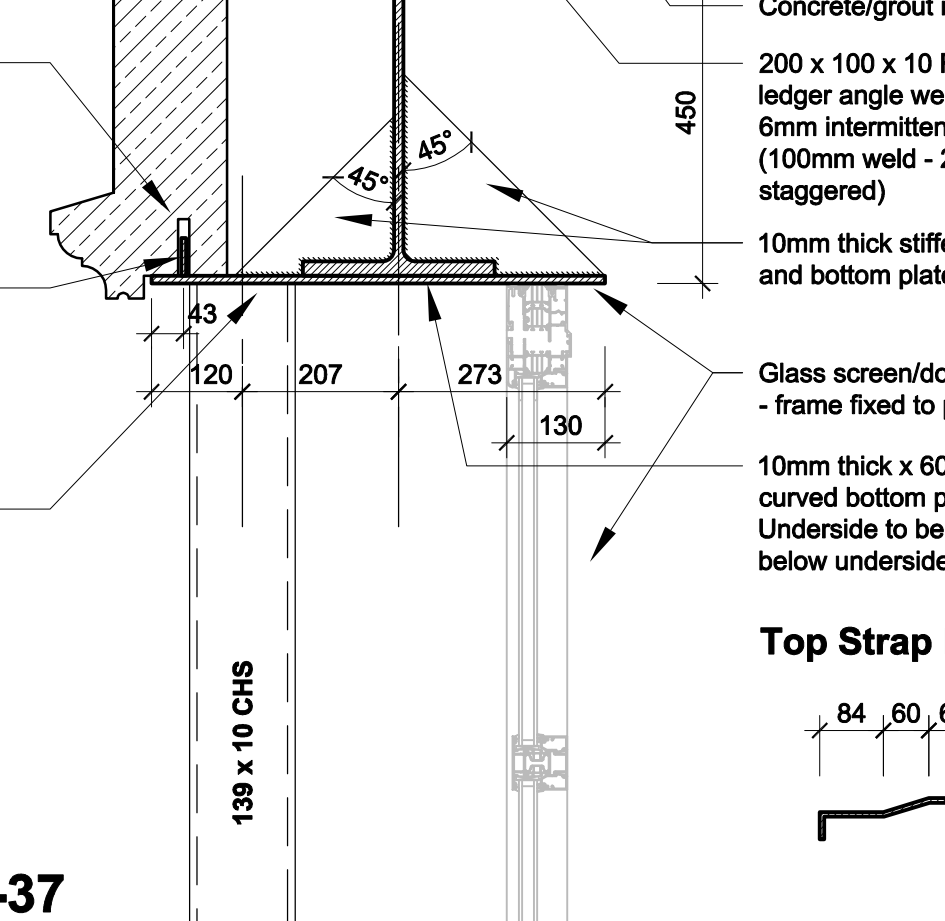

Detail 45-45

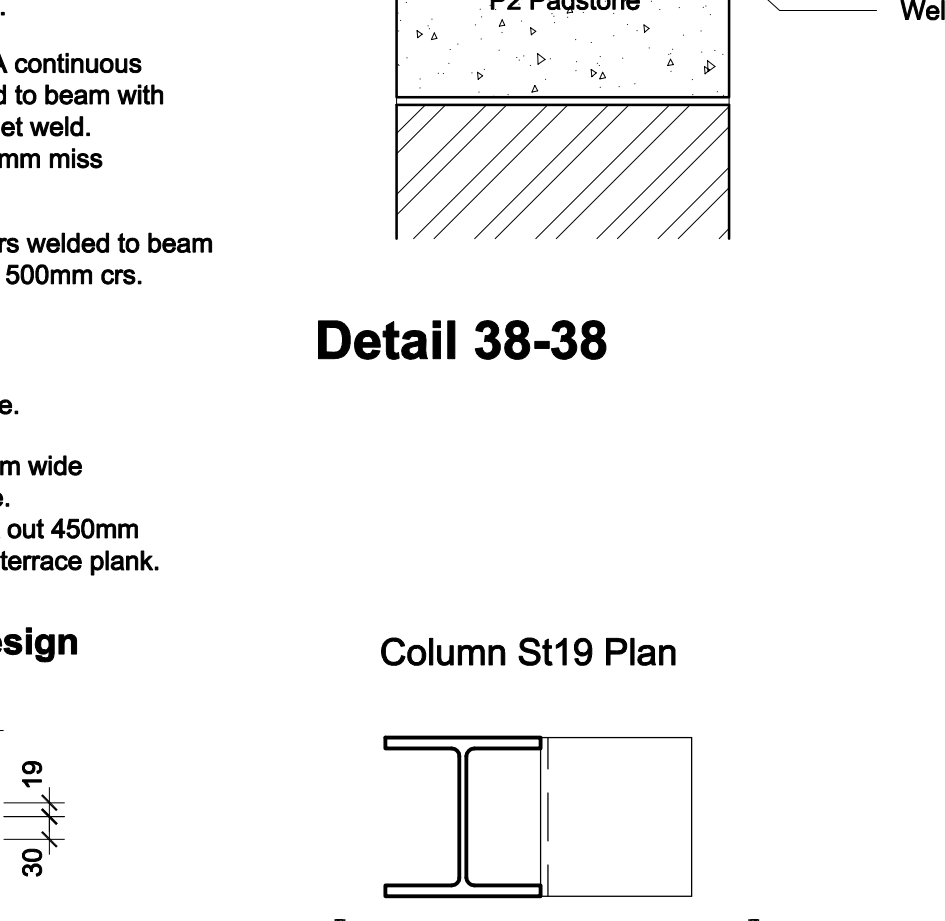

Detail 46-46

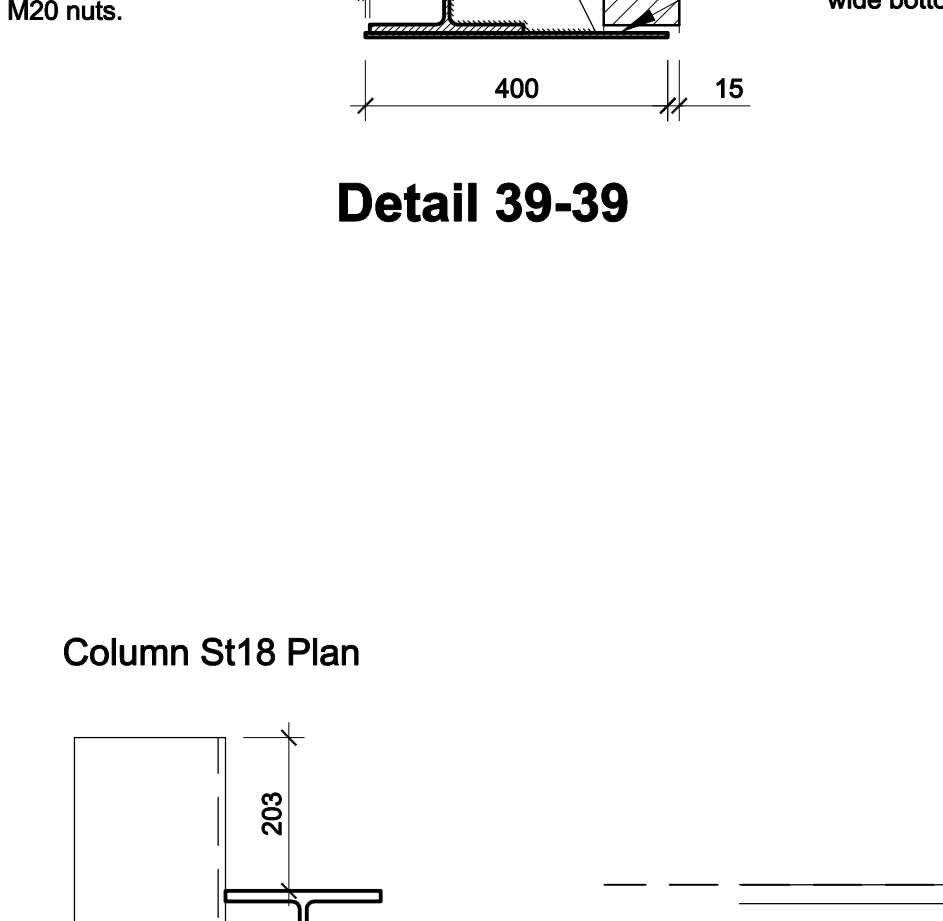

Detail 47-47

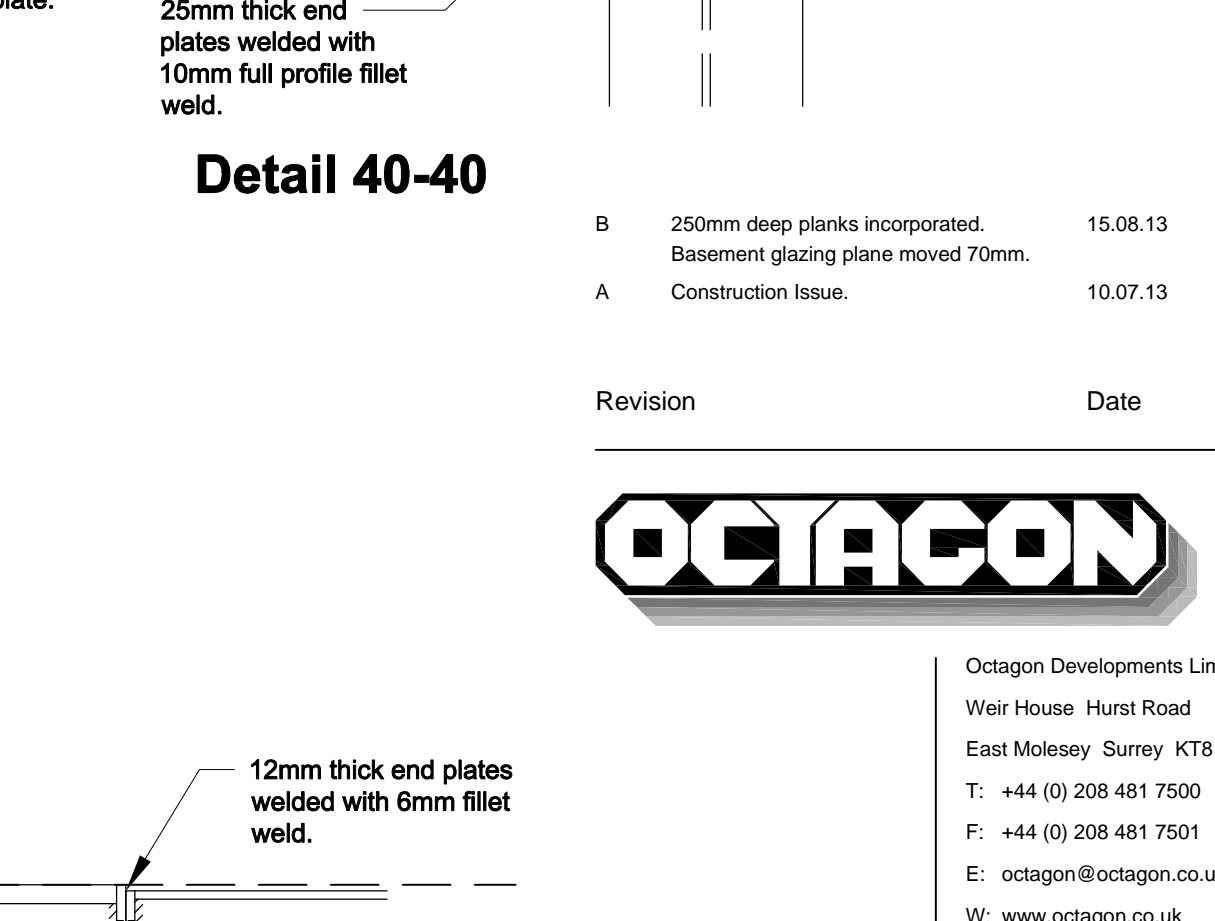

Detail 48-48

Revision table with columns for Revision, Date, and Description.

OCTAGON logo and contact information for Octagon Developments Limited, including address, phone, fax, email, and website.

Project information for Overby, St Georges Hill, including title, details, status, scale, date, and drawing number.