

PREFABRICATED TRUSSES,
LOOSE RAFTERS AND JOISTS TO
BE DESIGNED AND DETAILED BY
SPECIALIST MANUFACTURER

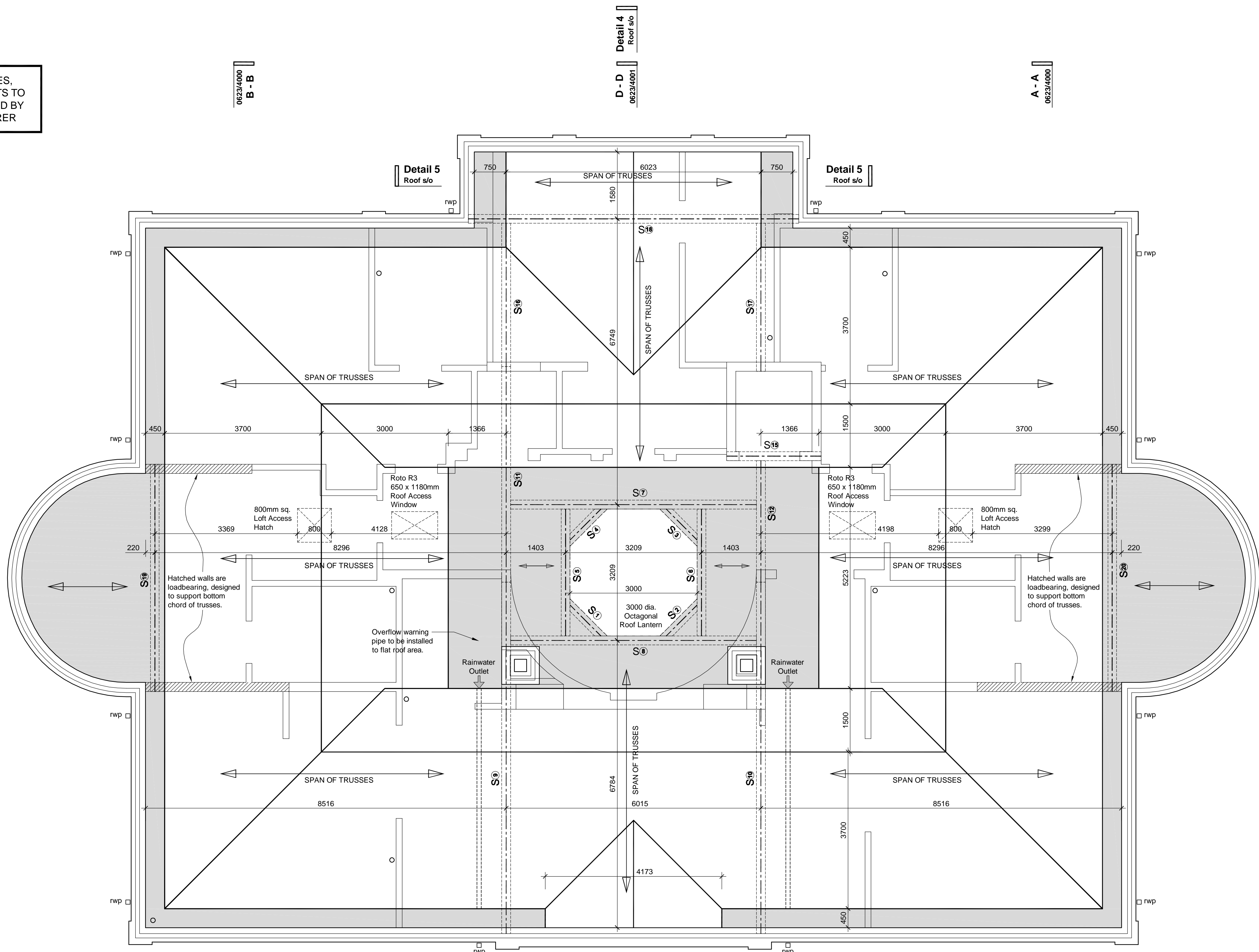

Roof Plan

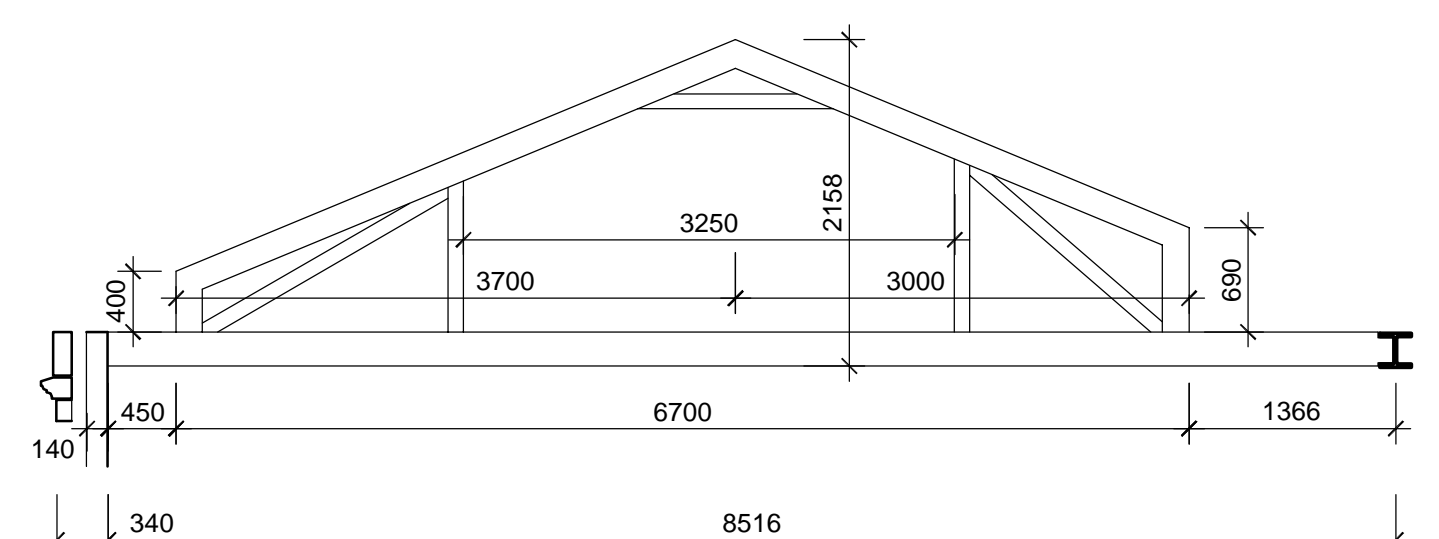

Detail 1
Roof Setting-Out (1:50)

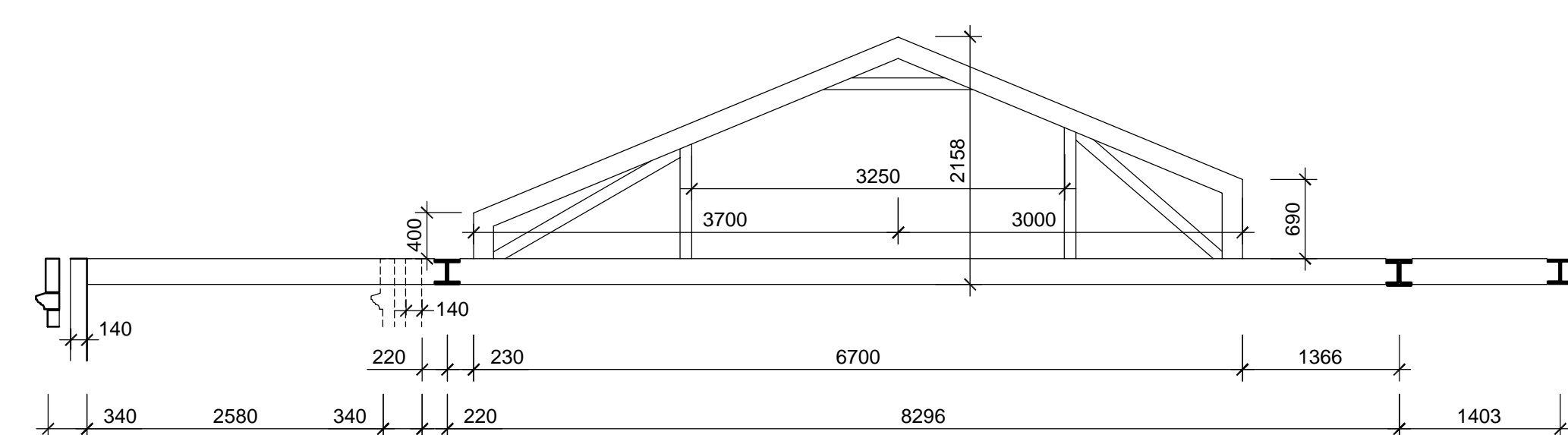

Detail 2
Roof Setting-Out (1:50)

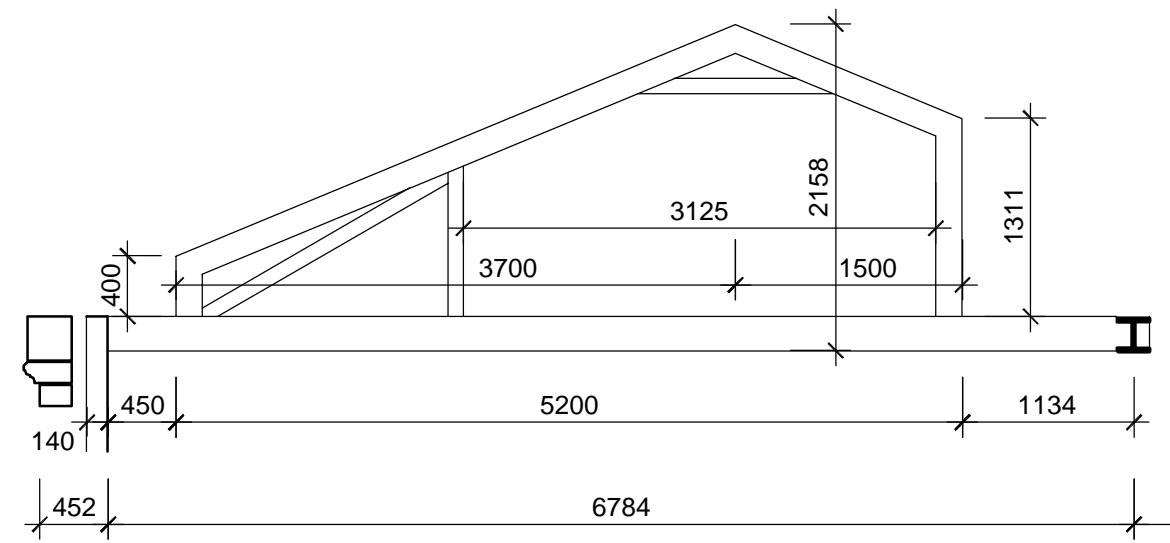

Detail 3
Roof Setting-Out (1:50)

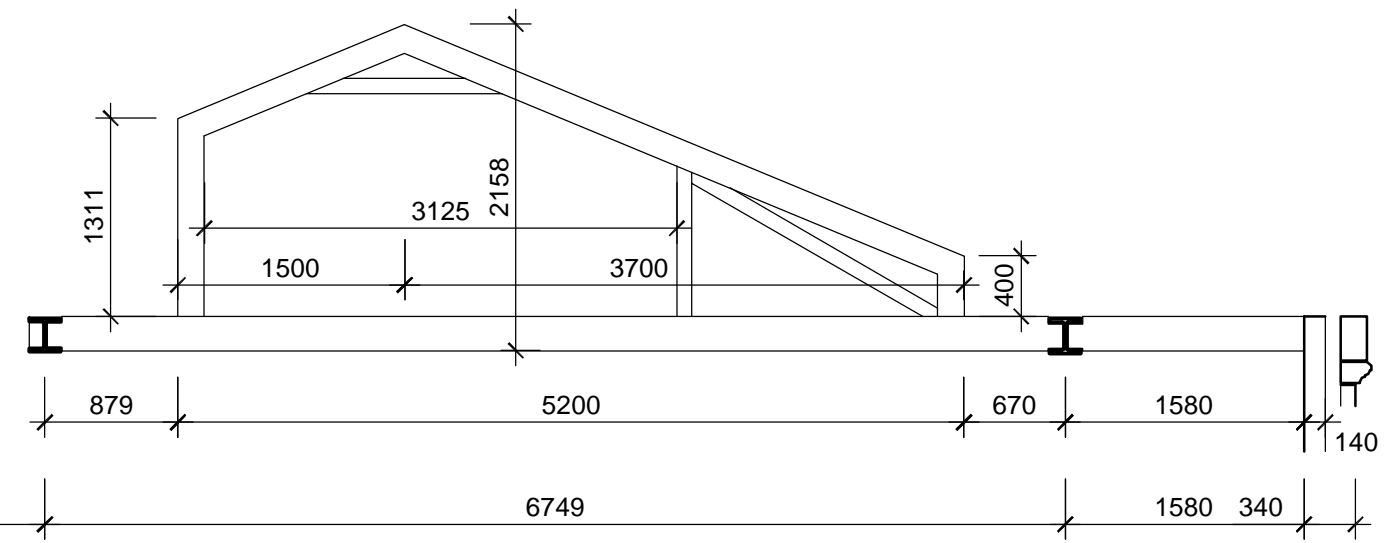

Detail 4
Roof Setting-Out (1:50)

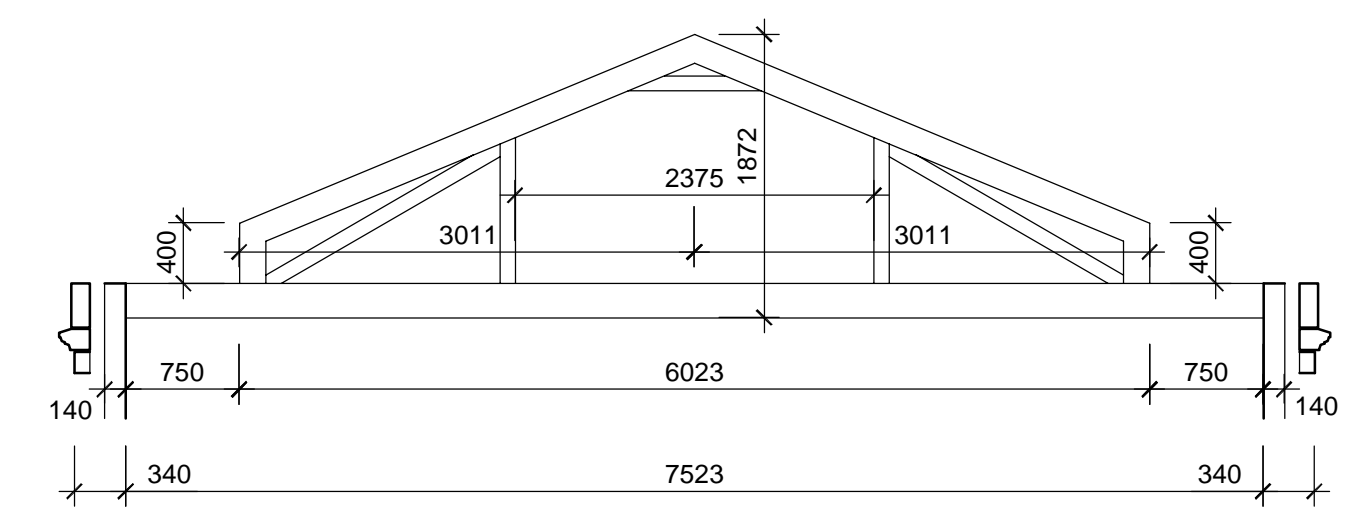

Detail 5
Roof Setting-Out (1:50)

Roof Details
Prefabricated trussed rafters, and all necessary loose rafters and joists by specialist manufacturer with saw bracing provided in accordance with B.S.5268 Part 3 1990.
Standard trusses spaced at max. 600mm c/c, and fixed to wall hangers with clips.
Trusses where supported by girder trusses to be fixed to metal hangers with all holes nailed.
Heavy duty hangers to be provided where specified by truss manufacturer.
All roof timbers are to be tanalised.
Wall plates to be bedded level and square and tied to blockwork with 30 x 5.0mm x 900mm long vertical restraint straps spaced at max 1200mm c/c.
Roof pitch to be 22½° throughout, unless shown otherwise.
Prestressed concrete lintels 300mm long x 100mm x 65mm deep to be provided as padstones below all multiple truss bearings.

Pitched Roof - (cold un-ventilated system) (0.16W/m²K U-Value):
Slate roof tiles as specification, fixed to 38 x 25mm sw battens laid at required gauge fixed to 50 x 38mm sw counter battens, on 1 No. layer of 'Tyvec' Supro 2506B breathable sarking felt, laid over roof trusses.
Roof constructed with prefabricated trussed rafters and loose timber in accordance with specialist manufacturer's details.
Roof pitch to be as stated on roof structure drawings.
300mm Rockwool Roll mineral fibre insulation (or similar approved) at ceiling joist level, with one 100mm insulation layer between ceiling joists & 2 layers of 100mm insulation cross layered over ceiling joists.
Underside of trusses lined with Tyvek SD2 air leakage barrier & with 1 layer 12.5mm plasterboard and skim coat finish.
All roof timbers are to be double vacuum treated with preservative.

Timber flat roof area of main roof - (warm un-ventilated system) (0.21W/m²K U-Value):
Warm deck construction consisting of 2 layer Andersons built-up roofing felt system utilising a type 3C perforated base felt (or two coat mastic asphalt on reinforced type 4A felt sheathing layer to BS 747) on 110mm total thickness Kingspan Thermafloor TR27 rigid urethane roof insulation (60mm board laid break bonded over 50mm board) not bitumen bonded to a previously applied aluminium felt (BS 747) vapour control layer over 18mm exterior quality plywood deck. Softwood firings to provide a minimum fall of 1:60 and laid on flat roof joist/tatic trusses at 400 c/c. (See plans for sizes).
Code 4 lead flashing to perimeter with minimum 75mm cover over min 150mm high felt upstand.
Underside of rafters to be lined with Tyvek SD2 air leakage barrier and finished with 12.5mm plasterboard lining, scrimmed and set.
All roof timbers are to be double vacuum treated with preservative.

Shaded area indicates flat roof/gutter.

D	Front gable gutters increased to 750mm. Rear gable setting out revised.	11.02.14
C	Wall revisions in accordance with First Floor plan.	18.10.13
B	Chimney stacks indicated	01.10.13
A	Construction Issue.	12.08.13

Revision	Date
----------	------

OCTAGON

Octagon Developments Limited
Warr House, Haverhill Road
East Molesey, Surrey, KT8 8AV
T: +44 (0) 208 481 7500
F: +44 (0) 208 481 7501
E: octagon@octagon.co.uk
W: www.octagon.co.uk

Project
Overbye, St Georges Hill
Title

Roof Layout Plan

Status	Construction	
Scale	Drawn	Date
1:50	sh	Mar. '13
Job number	Drawing number	Revision
0623	2006	D

© Copyright Octagon Developments Limited