

Detail 1-1 Detail 2-2

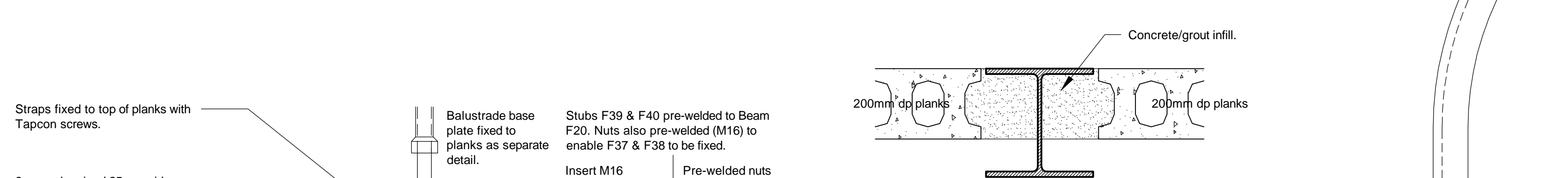

Detail 3-3

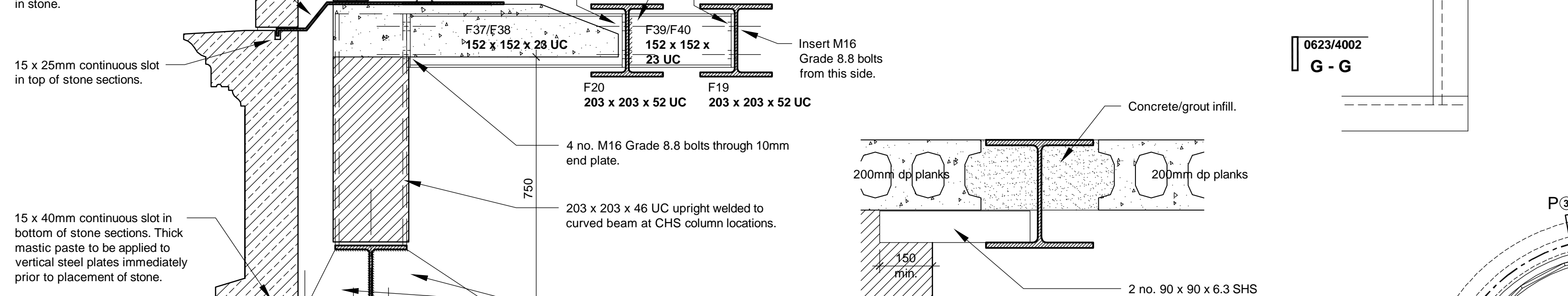

Detail 4-4

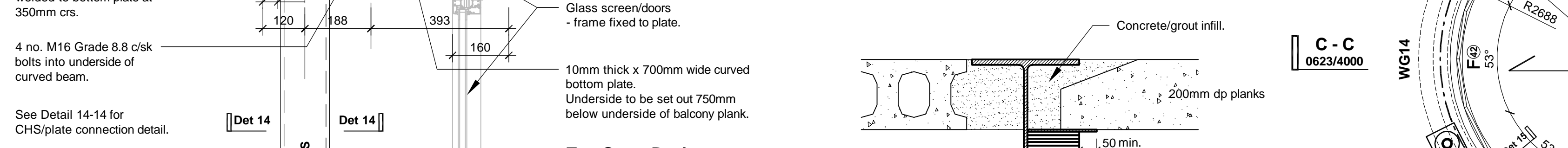

Detail 4a-4a

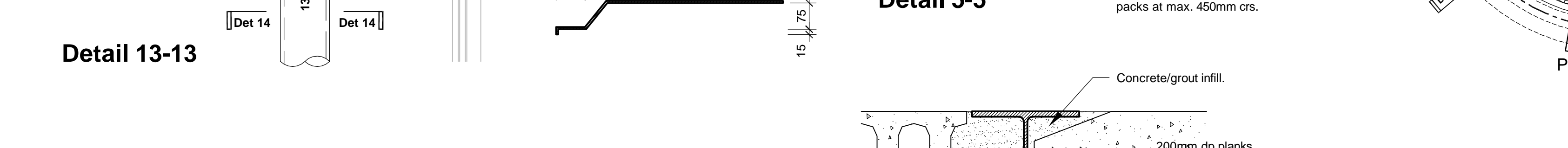

Detail 5-5



Detail 6-6



Detail 7-7



Detail 8-8



Detail 9-9

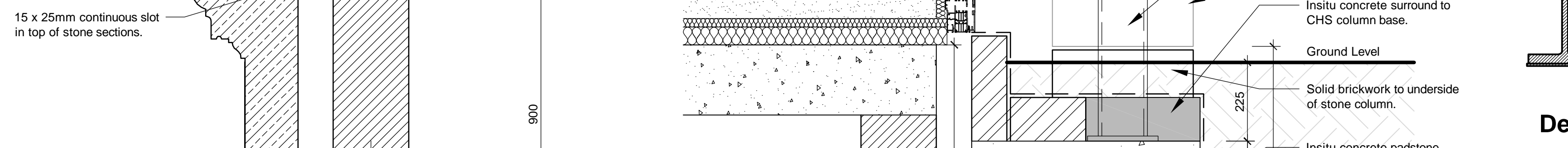

Detail 10-10

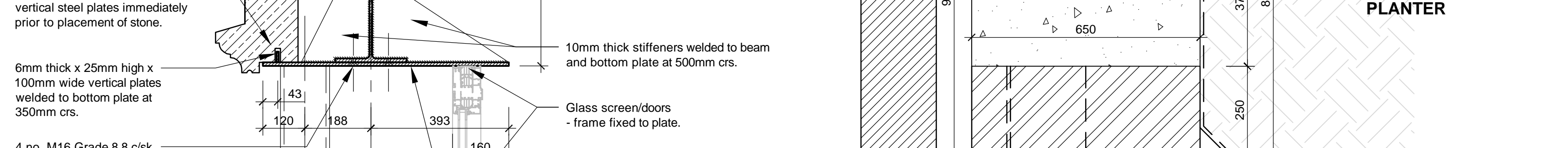

Detail 11-11

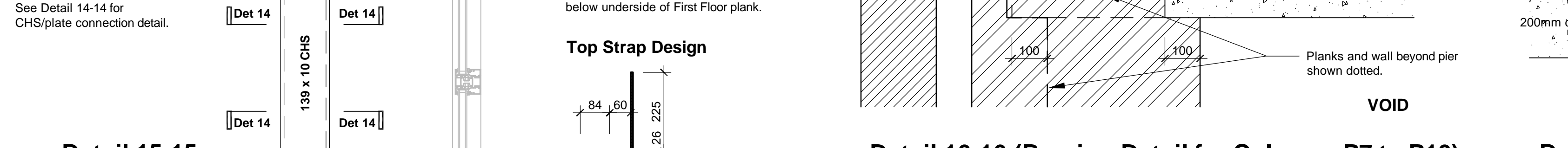

Detail 12-12



Detail 13-13



Detail 14-14



Detail 15-15



Detail 16-16 (Bearing Detail for Columns P7 to P10)



Detail 17-17



Detail 18-18



Detail 19-19



Detail 20-20



Detail 21-21



Detail 22-22



Detail 23-23



Detail 24-24



Detail 25-25



Detail 26-26



Detail 27-27



Detail 28-28



Detail 29-29



Detail 30-30



Detail 31-31



Detail 32-32



Detail 33-33



Detail 34-34



Detail 35-35



Detail 36-36



Detail 37-37



Detail 38-38



Detail 39-39



Detail 40-40



Detail 41-41



Detail 42-42



Detail 43-43



Detail 44-44



Detail 45-45



Detail 46-46



Detail 47-47



Detail 48-48



Detail 49-49



Detail 50-50



Detail 51-51



Detail 52-52



Detail 53-53



Detail 54-54



Detail 55-55



Detail 56-56



Detail 57-57



Detail 58-58



Detail 59-59



Detail 60-60



Detail 61-61



Detail 62-62



Detail 63-63



Detail 64-64



Detail 65-65



Detail 66-66



Detail 67-67



Detail 68-68



Detail 69-69



Detail 70-70

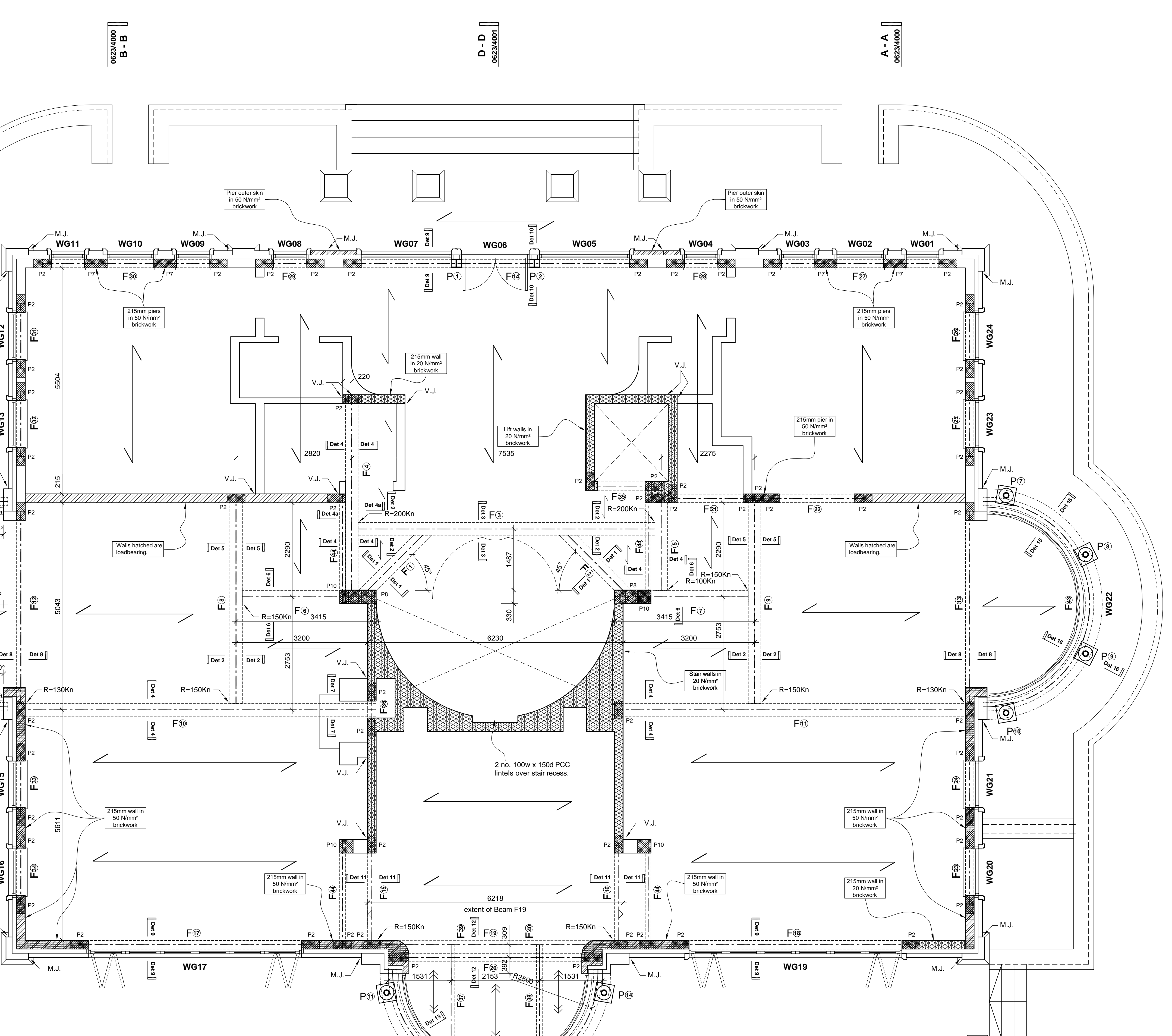

Ground Floor Plan showing - First Floor Structure

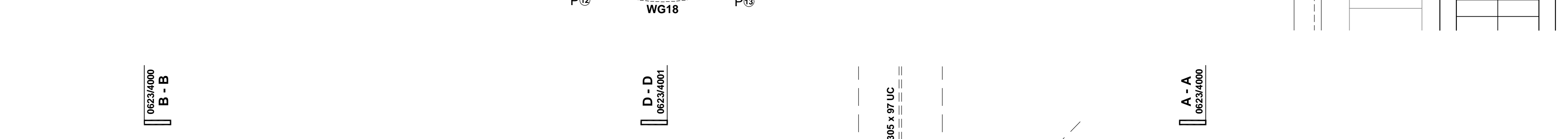

Detail 9-9

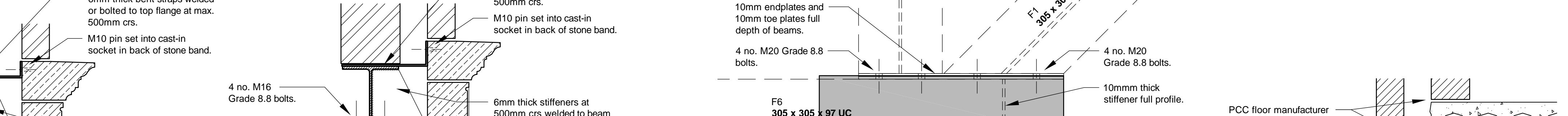

Detail 10-10

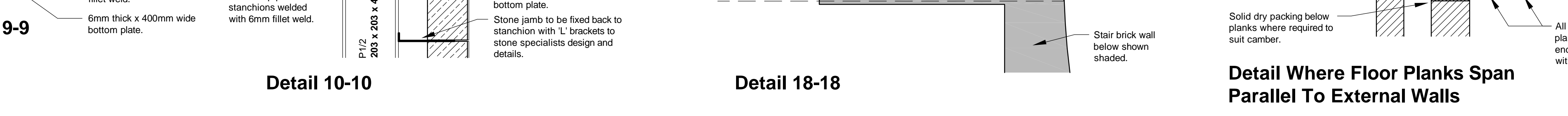

Detail 11-11



Detail 12-12

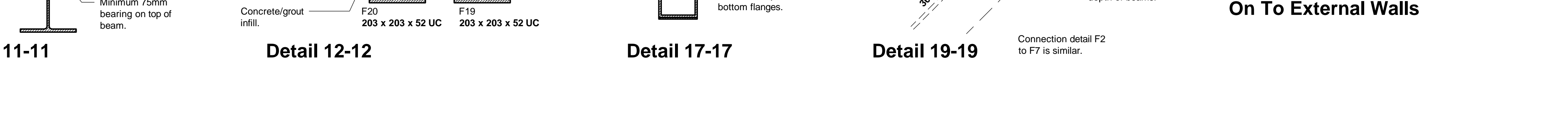

Detail 13-13



Detail 14-14



Detail 15-15



Detail 16-16



Detail 17-17



Detail 18-18



Detail 19-19



Detail 20-20



Detail 21-21



Detail 22-22



Detail 23-23



Detail 24-24



Detail 25-25



Detail 26-26



Detail 27-27



Detail 28-28

