

The M3V-Series In-line 3/2 Solenoid actuated valves provide an extensive range of flow options at low prices. The range may be used Lubrication free and be Manifold Mounted for multi-task applications. The Solenoid versions feature interchangeable coils and push/twist—lock Manual Overrides.



Specification

Model	3V210-06	3V220-06	3V210-08	3V220-08
Fluid	Air(to be filtered by 40um filter element)			
Acting	Internal piloted			
Port size ①	In=Out=1/8"		In=Out=1/4"	
Orifice size	14.0mm ² (Cv=0.78)		16.0mm ² (Cv=0.89)	
Valve type	3 port 2 position			
Lubrication ②	Not required			
Operating pressure	0.15-0.8MPa(21-114Psi)			
Proof pressure	1.5MPa(215Psi)			
Temperature °C	-20-70			
Material of body	Aluminum alloy			

Symbols

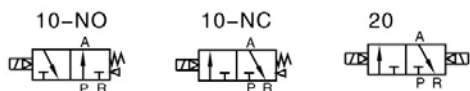

1. G (BSP) threads are standard (NPT threads are available as an option on request)
2. If lubrication is preferred, lubricants similar to ISO VG32 or equivalent are recommended.

Product Features

1. Internally pilot-solenoid operated valve series.
2. Spool type, with low leakage and low friction action.
3. Double solenoid valves have position memory using seal friction to retain the spool position.
4. Special manufacturing techniques ensure low start pressure and long service life.
5. Maybe used lubrication free.
6. The valve range may be manifold mounted for space saving and to reduce installation costs.
7. Push/twist-lock Manual Overrides are standard to assist with installation testing and debugging.
8. Several standard voltages are available with interchangeable coils.

Coil Specification

Item	Specification
Standard voltage	AC220V, AC110V, AC24V, DC24V, DC12V
Scope of voltage	AC: ± 15% DC: ± 10%
Power consumption	AC: 3.5VA DC : 3.0W
Protection	IP65 (DIN40050)
Temperature classification	B Class
Electrical entry	Terminal, Grommet
Activating time	0.05 sec and below

Flow Charts

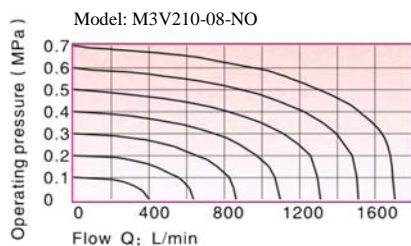
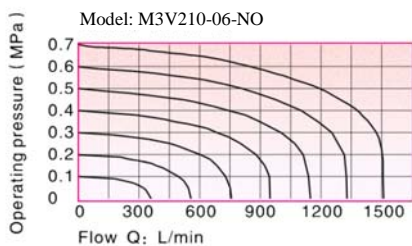

Model/Ordering Codes

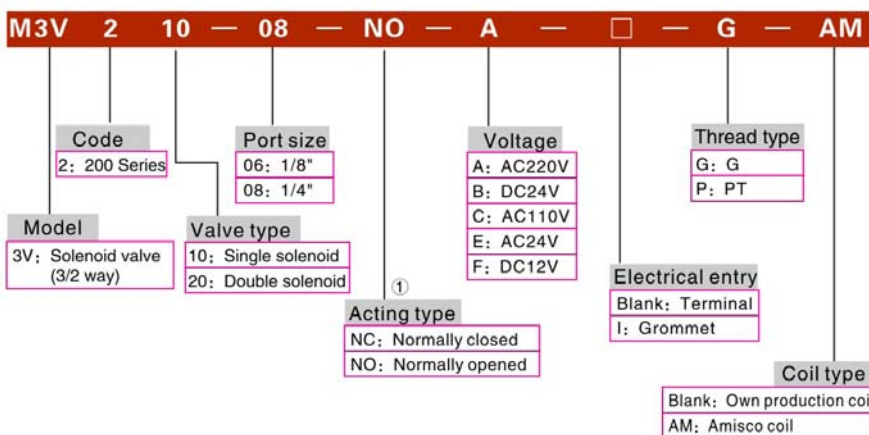

1. 2 position double solenoid versions have no difference between NO and NC, thus leave the code blank

Refer to In-line Valve Manifold section for mounting options

Inner structure

4V210

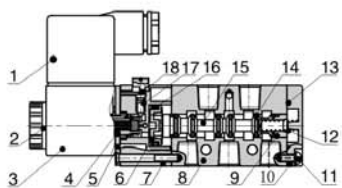

4V220

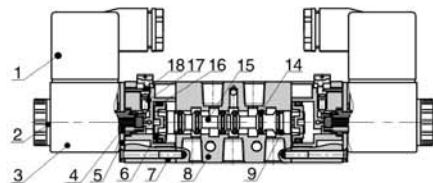

4V230C

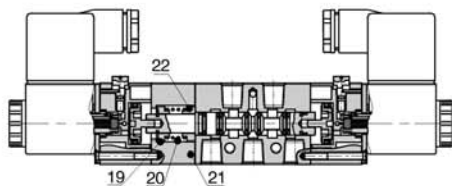

NO.	Item	NO.	Item	NO.	Item
1	Connector	9	Wearing ring	17	Override spring
2	Coil nut	10	Bottom cover	18	Manual override
3	Coil	11	Fixed screw	19	Spring holder
4	Armature	12	Spool spring	20	Return spring
5	Fixed plate	13	Bottom cover gasket	21	Side cover
6	Piston	14	Spool O-ring	22	Spring holder
7	Pilot kit	15	Spool		
8	Body	16	Piston O-ring		

Dimensions

4V210(Terminal)

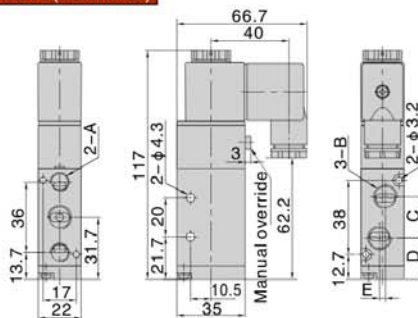

4V210(Grommet)

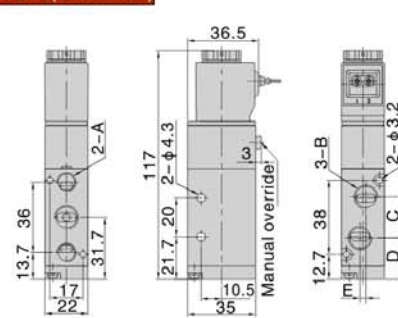

Model/Item	A	B	C	D	E
4V210-06	1/8"	1/8"	18	22.7	0
4V210-08	1/8"	1/4"	21	21.2	3

4V220(Terminal)

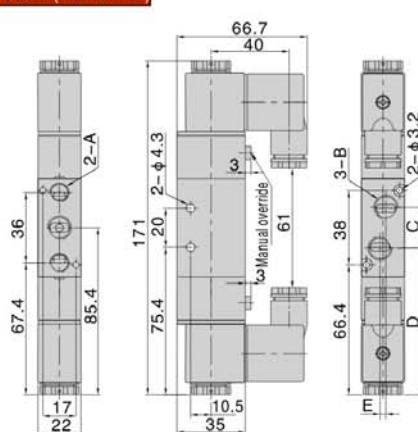

4V220(Grommet)

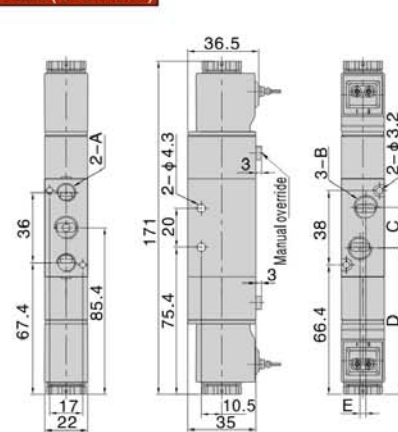

Model/Item	A	B	C	D	E
4V220-06	1/8"	1/8"	18	76.4	0
4V220-08	1/8"	1/4"	21	74.9	3

4V230(Terminal)

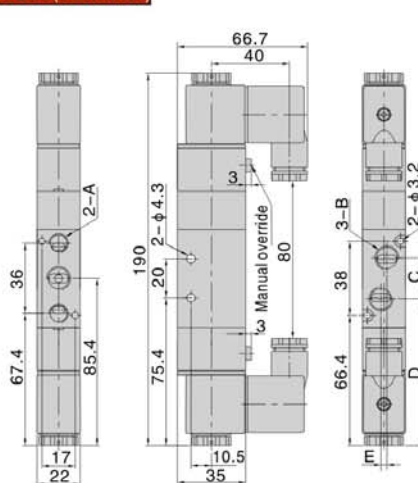

4V230(Grommet)

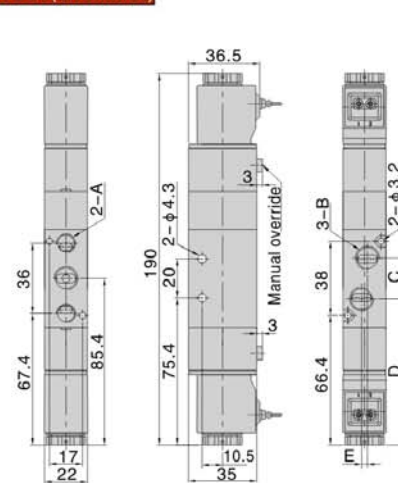

Model/Item	A	B	C	D	E
4V230-06	1/8"	1/8"	18	76.4	0
4V230-08	1/8"	1/4"	21	74.9	3